

DIGITAL MIXING ENGINE
DME64N / DME24N

Owner's Manual

DIGITAL MIXING ENGINE
DME64N

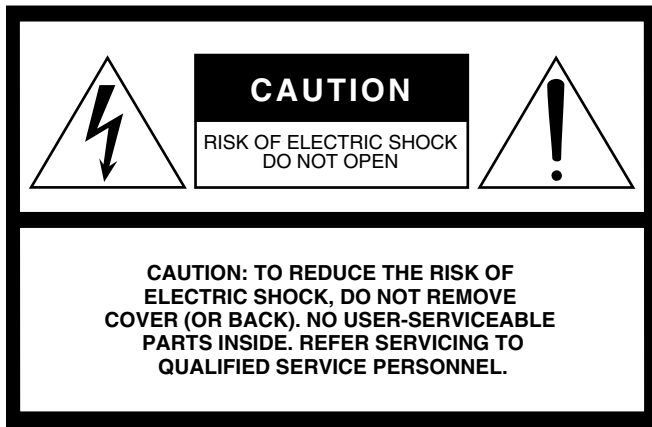

The above warning is located on the top of the unit.

Explanation of Graphical Symbols

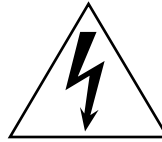

The lightning flash with arrowhead symbol within an equilateral triangle is intended to alert the user to the presence of uninsulated “dangerous voltage” within the product’s enclosure that may be of sufficient magnitude to constitute a risk of electric shock to persons.



The exclamation point within an equilateral triangle is intended to alert the user to the presence of important operating and maintenance (servicing) instructions in the literature accompanying the product.

IMPORTANT SAFETY INSTRUCTIONS

- 1 Read these instructions.
- 2 Keep these instructions.
- 3 Heed all warnings.
- 4 Follow all instructions.
- 5 Do not use this apparatus near water.
- 6 Clean only with dry cloth.
- 7 Do not block any ventilation openings. Install in accordance with the manufacturer’s instructions.
- 8 Do not install near any heat sources such as radiators, heat registers, stoves, or other apparatus (including amplifiers) that produce heat.
- 9 Do not defeat the safety purpose of the polarized or grounding-type plug. A polarized plug has two blades with one wider than the other. A grounding type plug has two blades and a third grounding prong. The wide blade or the third prong are provided for your safety. If the provided plug does not fit into your outlet, consult an electrician for replacement of the obsolete outlet.
- 10 Protect the power cord from being walked on or pinched particularly at plugs, convenience receptacles, and the point where they exit from the apparatus.
- 11 Only use attachments/accessories specified by the manufacturer.
- 12 Use only with the cart, stand, tripod, bracket, or table specified by the manufacturer, or sold with the apparatus. When a cart is used, use caution when moving the cart/apparatus combination to avoid injury from tip-over.
- 13 Unplug this apparatus during lightning storms or when unused for long periods of time.
- 14 Refer all servicing to qualified service personnel. Servicing is required when the apparatus has been damaged in any way, such as power-supply cord or plug is damaged, liquid has been spilled or objects have fallen into the apparatus, the apparatus has been exposed to rain or moisture, does not operate normally, or has been dropped.



WARNING

TO REDUCE THE RISK OF FIRE OR ELECTRIC SHOCK,
DO NOT EXPOSE THIS APPARATUS TO RAIN OR MOISTURE.

FCC INFORMATION (U.S.A.)

1. IMPORTANT NOTICE: DO NOT MODIFY THIS UNIT!

This product, when installed as indicated in the instructions contained in this manual, meets FCC requirements. Modifications not expressly approved by Yamaha may void your authority, granted by the FCC, to use the product.

2. IMPORTANT:

When connecting this product to accessories and/or another product use only high quality shielded cables. Cable/s supplied with this product MUST be used. Follow all installation instructions. Failure to follow instructions could void your FCC authorization to use this product in the USA.

3. NOTE:

This product has been tested and found to comply with the requirements listed in FCC Regulations, Part 15 for Class "B" digital devices. Compliance with these requirements provides a reasonable level of assurance that your use of this product in a residential environment will not result in harmful interference with other electronic devices. This equipment generates/uses radio frequencies and, if not installed and used according to the instructions found in the users manual, may cause interference harmful to the operation of other electronic devices. Compliance with FCC regulations does

not guarantee that interference will not occur in all installations. If this product is found to be the source of interference, which can be determined by turning the unit "OFF" and "ON", please try to eliminate the problem by using one of the following measures:

Relocate either this product or the device that is being affected by the interference.

Utilize power outlets that are on different branch (circuit breaker or fuse) circuits or install AC line filter/s.

In the case of radio or TV interference, relocate/reorient the antenna. If the antenna lead-in is 300 ohm ribbon lead, change the lead-in to co-axial type cable.

If these corrective measures do not produce satisfactory results, please contact the local retailer authorized to distribute this type of product. If you can not locate the appropriate retailer, please contact Yamaha Corporation of America, Electronic Service Division, 6600 Orangethorpe Ave, Buena Park, CA90620

The above statements apply ONLY to those products distributed by Yamaha Corporation of America or its subsidiaries.

* This applies only to products distributed by YAMAHA CORPORATION OF AMERICA.

(class B)

IMPORTANT NOTICE FOR THE UNITED KINGDOM Connecting the Plug and Cord

WARNING: THIS APPARATUS MUST BE EARTHED
IMPORTANT. The wires in this mains lead are coloured in accordance with the following code:

GREEN-AND-YELLOW	:	EARTH
BLUE	:	NEUTRAL
BROWN	:	LIVE

As the colours of the wires in the mains lead of this apparatus may not correspond with the coloured markings identifying the terminals in your plug proceed as follows:

The wire which is coloured GREEN-and-YELLOW must be connected to the terminal in the plug which is marked by the letter E or by the safety earth symbol  or colored GREEN or GREEN-and-YELLOW.

The wire which is coloured BLUE must be connected to the terminal which is marked with the letter N or coloured BLACK.

The wire which is coloured BROWN must be connected to the terminal which is marked with the letter L or coloured RED.

• This applies only to products distributed by Yamaha-Kemble Music (U.K.) Ltd. (3 wires)

ADVARSEL!

Lithiumbatteri—Eksplodingsfare ved fejlagtig håndtering. Udskiftning må kun ske med batteri af samme fabrikat og type. Levér det brugte batteri tilbage til leverandoren.

VARNING

Explosionsfara vid felaktigt batteribyte. Använd samma batterityp eller en ekvivalent typ som rekommenderas av apparattillverkaren. Kassera använt batteri enligt fabrikantens instruktion.

VAROITUS

Paristo voi räjähtää, jos se on virheellisesti asennettu. Vaihda paristo ainoastaan laitevalmistajan suosittelemaan tyyppiin. Hävitä käytetty paristo valmistajan ohjeiden mukaisesti.

(lithium caution)

This product contains a battery that contains perchlorate material. Perchlorate Material—special handling may apply, See www.dtsc.ca.gov/hazardouswaste/perchlorate.

• This applies only to products distributed by YAMAHA CORPORATION OF AMERICA. (Perchlorate)

NEDERLAND / THE NETHERLANDS

- Dit apparaat bevat een lithium batterij voor geheugen back-up.
- This apparatus contains a lithium battery for memory back-up.
- Raadpleeg uw leverancier over de verwijdering van de batterij op het moment dat u het apparaat aan het einde van de levensduur of gelieve dan contact op te nemen met de vertegenwoordiging van Yamaha in uw land.
- For the removal of the battery at the moment of the disposal at the end of life please consult your retailer or Yamaha representative office in your country.
- Gooi de batterij niet weg, maar lever hem in als KCA.
- Do not throw away the battery. Instead, hand it in as small chemical waste.

(lithium disposal)

PRECAUTIONS

PLEASE READ CAREFULLY BEFORE PROCEEDING

* Please keep this manual in a safe place for future reference.



WARNING

Always follow the basic precautions listed below to avoid the possibility of serious injury or even death from electrical shock, short-circuiting, damages, fire or other hazards. These precautions include, but are not limited to, the following:

Power supply/Power cord

- Only use the voltage specified as correct for the device. The required voltage is printed on the name plate of the device.
- Use only the specified power cord.
- Do not place the power cord near heat sources such as heaters or radiators, and do not excessively bend or otherwise damage the cord, place heavy objects on it, or place it in a position where anyone could walk on, trip over, or roll anything over it.
- Be sure to connect to an appropriate outlet with a protective grounding connection. Improper grounding can result in electrical shock.

Do not open

- Do not open the device or attempt to disassemble the internal parts or modify them in any way. The device contains no user-serviceable parts. If it should appear to be malfunctioning, discontinue use immediately and have it inspected by qualified Yamaha service personnel.

Water warning

- Do not expose the device to rain, use it near water or in damp or wet conditions, or place containers on it containing liquids which might spill into any openings.
- Never insert or remove an electric plug with wet hands.

If you notice any abnormality

- If the power cord or plug becomes frayed or damaged, or if there is a sudden loss of sound during use of the device, or if any unusual smells or smoke should appear to be caused by it, immediately turn off the power switch, disconnect the electric plug from the outlet, and have the device inspected by qualified Yamaha service personnel.
- If this device should be dropped or damaged, immediately turn off the power switch, disconnect the electric plug from the outlet, and have the device inspected by qualified Yamaha service personnel.



CAUTION

Always follow the basic precautions listed below to avoid the possibility of physical injury to you or others, or damage to the device or other property. These precautions include, but are not limited to, the following:

Power supply/Power cord

- Remove the electric plug from the outlet when the device is not to be used for extended periods of time, or during electrical storms.
- When removing the electric plug from the device or an outlet, always hold the plug itself and not the cord. Pulling by the cord can damage it.

Location

- Before moving the device, remove all connected cables.
- When setting up the device, make sure that the AC outlet you are using is easily accessible. If some trouble or malfunction occurs, immediately turn off the power switch and disconnect the plug from the outlet. Even when the power switch is turned off, electricity is still flowing to the product at the minimum level. When you are not using the product for a long time, make sure to unplug the power cord from the wall AC outlet.
- Avoid setting all equalizer controls and faders to their maximum. Depending on the condition of the connected devices, doing so may cause feedback and may damage the speakers.
- Do not expose the device to excessive dust or vibrations, or extreme cold or heat (such as in direct sunlight, near a heater, or in a car during the day) to prevent the possibility of panel disfiguration or damage to the internal components.
- Do not place the device in an unstable position where it might accidentally fall over.

- Do not block the vents. This device has ventilation holes at the front and rear to prevent the internal temperature from rising too high. In particular, do not place the device on its side or upside down, or place it in any poorly-ventilated location, such as a bookcase or closet.
- Do not use the device in the vicinity of a TV, radio, stereo equipment, mobile phone, or other electric devices. Otherwise, the device, TV, or radio may generate noise.

Connections

- Before connecting the device to other devices, turn off the power for all devices. Before turning the power on or off for all devices, set all volume levels to minimum.
- Be sure to connect to a properly grounded power source. A ground screw terminal is provided on the rear panel for safely grounding the device and preventing electrical shock.

Maintenance

- Remove the power plug from the AC outlet when cleaning the device.

Handling caution

- Do not insert your fingers or hand in any gaps or openings on the device (vents, ports, etc.).
- Condensation can occur in the device due to rapid, drastic changes in ambient temperature—when the device is moved from one location to another, or air conditioning is turned on or off, for example. Using the device while condensation is present can cause damage. If there is reason to believe that condensation might have occurred, leave the device for several hours without turning on the power until the condensation has completely dried out.
- Avoid inserting or dropping foreign objects (paper, plastic, metal, etc.) into any gaps or openings on the device (vents, ports, etc.) If this happens, turn off the power immediately and unplug the power cord from the AC outlet. Then have the device inspected by qualified Yamaha service personnel.
- Do not use the device or headphones for a long period of time at a high or uncomfortable volume level, since this can cause permanent hearing loss. If you experience any hearing loss or ringing in the ears, consult a physician.
- Do not rest your weight on the device or place heavy objects on it, and avoid use excessive force on the buttons, switches or connectors.

Do not turn the [POWER] switch on and off repeatedly and rapidly. Be sure to wait six seconds or more between turning the power to the unit off and then on.

Yamaha cannot be held responsible for damage caused by improper use or modifications to the device, or data that is lost or destroyed.

Always turn the power off when the device is not in use.

The performance of components with moving contacts, such as switches, volume controls, and connectors, deteriorates over time. Consult qualified Yamaha service personnel about replacing defective components.

- The illustrations in this document are for instructional purposes, and may appear somewhat different from the actual equipment.
- The bitmap fonts used in this device have been provided by and are the property of Ricoh Co., Ltd.
- CobraNet and Peak Audio are trademarks of Cirrus Logic, Inc.
- Ethernet is a trademark of Xerox Corporation.
- All other trademarks are the property of their respective holders and are hereby acknowledged.

Backup battery

This device has a built-in backup battery that maintains data in internal memory even when the device's power is switched off. The backup battery will eventually become depleted, however, and when that happens the contents of the internal memory will be lost.* To prevent loss of data be sure to replace the backup battery before it becomes fully depleted. When the remaining capacity of the backup battery becomes so low that it needs to be replaced a "Low Battery" or "No Battery" message will appear on the display during operation or when the device is powered on. If either of these messages appears do not turn off the power and immediately transfer any data you want to save to a computer or other external storage device, then have qualified Yamaha service personnel replace the backup battery. The average life of the internal backup battery is approximately 5 years, depending on operating conditions.

* Data items maintained in the internal memory by the backup battery are as follows:

- Current scene parameters and number.
- Device parameters (SLOT, HA, UTILITY, Master Mute/Level, etc.).
- Event log.

Data items other than those described above are stored in memory that does not require backup power, and will be retained even if the backup battery fails.

Foreword

Thank you for choosing a Yamaha DME64N/24N Digital Mixing Engine.

Using the supplied DME Designer software, the DME64N and DME24N can be easily configured to handle a wide range of audio processing applications – institutional audio installations, sub-mixing, speaker system control, matrix and routing, multi-effect processing, and much more.

In order to take full advantage of the features and performance provided by the DME64N/24N, we urge you to read this owner's manual thoroughly before use, and keep it in a safe place for future reference.

The Yamaha Pro Audio web site is at: <http://www.yamahaproaudio.com/>

Contents

Foreword	8
Accessories (Please make sure the following items are included in the package.)	8
Options	8
About the Product Names	8
About the Firmware Version	8
Preparation	8
Connecting the AC power cord	8
Turning the power on and off.	8
Introduction to the DME64N/24N	9
Differences between DME64N/24N	9
DME64N/24N Features	9
Audio System Network	9
Glossary for the DME64N/24N	9
Signal Types	11
System Examples	12
About DME Designer	13
The Controls and Connectors	14
Front Panel	14
Rear Panel	16
Setup	18
Setup Procedure.	18
I/O Card Installation	20
Compatible I/O Cards	20
I/O Card Installation Procedure	21
Connecting to a Computer	22
USB Connection	22
Ethernet Connection ([NETWORK] Connector)	23
Audio I/O Connection	26
Analog Audio Connection ([IN] and [OUT] Connectors) (DME24N only).	26
I/O Slots.	27
Connecting to an External Device	28
Remote Connection ([REMOTE] Connector).	28
Controlling external head amplifiers from the DME64N/24N	28
Controlling a DME24N's internal head amps from a digital mixer	29
Controlling the DME64N/24N from an external device	29
MIDI Connection ([MIDI] Connectors)	30
Cascade Connection ([Cascade] Connectors) (DME64N only)	31

WORD CLOCK Connection ([WORD CLOCK] Connectors)	32
GPI Connection ([GPI] Connectors)	33
Panel Operation and Displays	34
Basic Operation	34
Main Display	35
Parameter Edit Displays.	36
Editing User Defined Button	38
Mute Switching	39
Output Level Control	39
Scene Recall	39
Scene Store	40
Monitoring	40
Spectrum Display.	41
Level Meter Display.	42
Initializing the DME64N/DME24N	43
Utility Displays	44
Items accessible via the Utility display.	44
Utility Display Operation	46
Info Page.	46
Network Settings (Net) Page.	47
Display Setup (Disp) Page	47
Security Setup (Lock) Page	48
Miscellaneous Setup (Misc) Page	49
Word Clock Setup (WCLK) Page.	50
Slot Information (Slot) Page	51
MIDI Setup (MIDI) Page.	51
GPI Setup (GPI) Page.	53
Head Amplifier Setup (HA) Page	54
Cascade Setup (CASCAD) Page	55
Check Page.	56
References	57
Options	57
ICP1	57
CP4SW, CP4SF, and CP1SF	57
Error Messages.	58
Troubleshooting	61
Specifications	62
Input/Output Characteristics.	63
Control I/O	63
Connector Pin Assign	65
Dimensions	67
MIDI Data Format	68
Glossary	73
Index	75

Foreword
Introduction to the DME64N/24N
The Controls and Connectors
Preparation
Connecting to a Computer
Audio I/O Connection
Connecting to an External Device
Panel Operation and Displays
References

Foreword

Thank you for choosing a Yamaha DME64N/24N Digital Mixing Engine.

In order to take full advantage of the features and performance provided by the DME64N/24N, we urge you to read this owner's manual thoroughly before connecting or using the unit. Keep this manual in a safe place for future reference.

Accessories (Please make sure the following items are included in the package.)

- DME64N/DM24N Owner's Manual (This document)
- AC power cord
- AC plug clamp
- Euroblock plug (16P) x 2
- Euroblock plug (8P) x 4 (DME64N only)
- Euroblock plug (3P) x 16 (DME24N only)

Options

Control Panels

- ICP1 Intelligent Control Panel
- CP4SW Control Panel
- CP4SF Control Panel
- CP1SF Control Panel

NOTE

For more information on your Control Panel, refer to the owner's manual that came with the Control Panel, as well as the DME Designer Owner's Manual.

About the Product Names

In this manual, models DME64N, DME24N, DME8i-C, DME8o-C, DME4io-C, DME8i-ES, DME8o-ES and DME4io-ES are categorized as DME series, and models DME8i-C, DME8o-C, DME4io-C, DME8i-ES, DME8o-ES and DME4io-ES are all called the "DME Satellite".

About the Firmware Version

You can download the latest firmware from the following Yamaha website.

<http://www.yamahaproaudio.com/downloads/>

Preparation

Connecting the AC power cord



Be sure to turn all devices OFF before connecting AC mains power.

First plug the female-connector end of the AC cord into the [AC IN] socket on the rear panel of the DME64N/24N, then plug the male plug into an appropriate AC mains outlet.

Be sure to use the voltage specified for the device.

Turning the power on and off



To prevent the initial power-on surge from generating a large noise spike or damaging your speaker system, turn the devices on in the following order: audio sources, mixer (such as M7CL or PM5D), DME64N/24N, and finally power amplifiers. Reverse this order when turning power off.

1. Press the [POWER] switch to turn on the power to the DME64N/24N.
2. Press the [POWER] switch again to turn off the power.

NOTE

The DME64N/24N remembers scene settings when you turn off the power.

When you turn on the power to the DME64N/24N, it will start up with the same scene settings.

You can set up the DME64N/24N so that at the startup it will recall the scene selected before you turned off the power to the device. (page 49)



Do NOT turn off the power to the DME64N/24N while it is receiving data from DME Designer or while it is being manipulated from an external device. Otherwise, a malfunction may occur.



Even when the power switch is turned off, electricity is still flowing to the product all the minimum level. When you are not using the product for a long time, make sure to unplug the power cord from the wall AC outlet.

Introduction to the DME64N/24N

Differences between DME64N/24N

The DME64N has four I/O card slots, while the DME24N has one I/O card slot and eight channels of built-in analog audio I/O.

A single I/O card can handle up to 16 channels of audio I/O, so the DME64N can handle a maximum of 64 audio I/O channels. The DME24N can handle up to 24 audio I/O channels.

The DME64N has approximately double the DSP processing power of the DME24N.

DME64N/24N Features

In addition to basic mixing and matrix output functions, the DME64N/24N includes a equalizers, compressors, delay, etc. – that can be patched together via DME Designer to configure just about any audio system you need.

Audio System Network

Multiple DME series units that are interconnected in a network via Ethernet function as a single audio system. In a DME audio system, a group of the same models that can be operated in sync is called a “device group;” audio processing divisions that accommodate multiple device groups are called “zones;” and the entire area serviced by the acoustic system is called an “area.”

Each device group always includes one DME series unit that functions as the “group master” and controls all other DME series units in the same device group.

If a computer is connected to the network, you can use the computer to control an entire device group via the group master.

Glossary for the DME64N/24N

This section explains terminology specific to the DME64N/24N.

Components and parameters

The individual audio processing modules (equalizers, compressors, etc.) are called “components.”

External head amplifier control modules are also available as components.

Changing the parameters of components enables control over the operation of the components.

Configuration

A “configuration” is a complete set of components for constructing an audio system.

Each configuration determines the audio function(s) of the corresponding DME64N/24N unit.

All parameter sets included with each component in a configuration are called “preset parameters.”

One DME64N/24N unit has a number of configurations, and a configuration has a number of preset parameters.

User Defined buttons

Assigning parameters to be User Defined Buttons enables you to control the device from the ICP1 and the DME64N/DME24N.

Refer to the DME Designer Owner’s Manual for details.

Scene

A combination of all configuration and preset parameters is called a “scene.”

Scenes can be recalled from an ICP1, GPI device, other external controllers, DME64N/DME24N, or computer.

Up to 999 scenes can be stored for each device group.

Scene structure

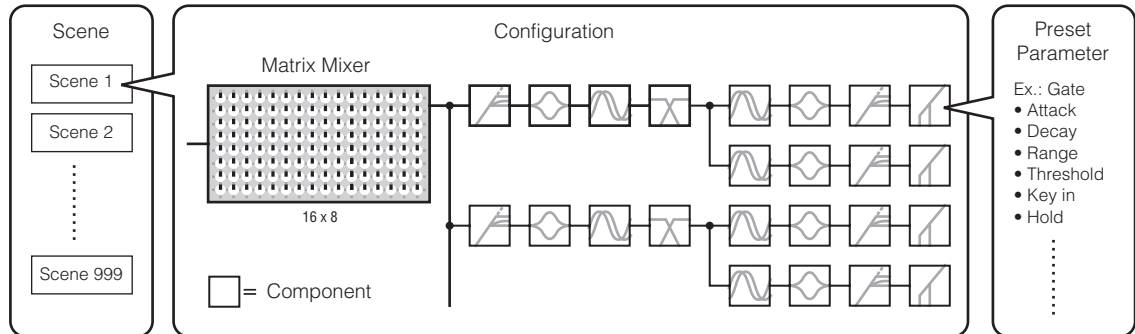

Scene change

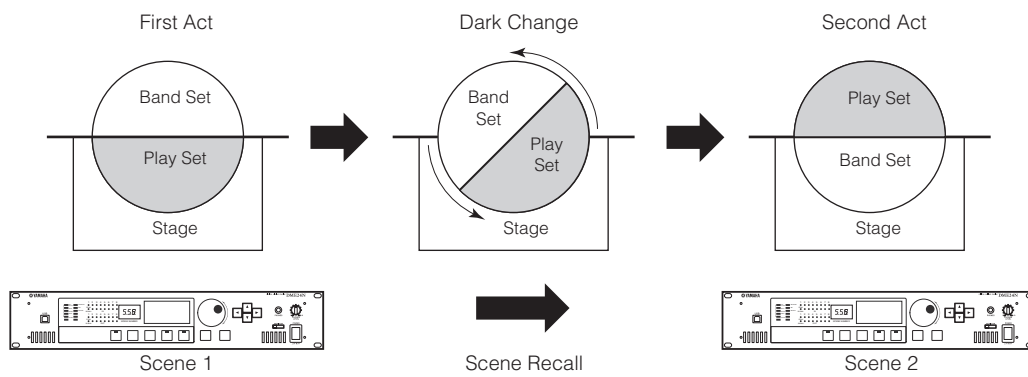

Signal Types

DME64N/24N audio system signals can be broadly categorized as follows.

1 Audio

The DME64N/24N will be required to send and receive audio signals to and from other DME series units as well as other audio equipment.

Audio signal transmission and reception will occur primarily via the [INPUT] and [OUTPUT] connectors on the DME24N.

2 Control signals within a device group

Device group control signals control all DME series devices in the group.

There are two types of device group control signals, as follows:

- **Control signals between the computer and the group master DME series unit**
- **Control signals between the group master DME series unit and the other DME series units**

You can use the DME Designer application to control the entire device group, such as sending components to the devices and setting the parameters as required.

3 Control signals between devices outside the device group

These signals provide communication and control between individual devices.

Included in this category are MIDI messages transferred between [USB] connectors, GPI signals transferred between [GPI] connectors, and remote head amp control signals handled via the [REMOTE] connector.

Type of signals handled by the DME64N/24N

Connector	Audio Signal	Device Control	Word Clock	Reference Page
[USB] Connector	–	<ul style="list-style-type: none"> • Control signals between computer and DME64N/24N • MIDI messages 	–	22
[NETWORK] Connector	–	<ul style="list-style-type: none"> • Control signals between computer and DME64N/24N • Control signals between DME series unit. 	–	23
[MIDI] Connector	–	Control signals (MIDI commands) between MIDI controller and DME64N/24N.	–	30
[GPI] Connector	–	Control signals between GPI device (GPI controller, etc.) and DME series unit	–	33
[CASCADE] Connector (DME64N only)	32 channels of input/output.	Control signals from the digital mixer to the DME64N	Word clock transmission and reception to and from other devices.	31
[WORD CLOCK] Connector	–	–	Word clock transmission and reception to and from other devices.	32
[REMOTE] Connector	–	<ul style="list-style-type: none"> • Control signals to/from an external device (such as AD8HR head amplifier) • Control signals for a digital mixer and internal head amp • Control signals with a controller such as an AMX or Crestron • MIDI messages 	–	28
(Audio I/O Connectors) (DME24N only)	8 channels of input and output.	–	–	26
(I/O Slot)	Number of I/O channels depends on card.	Serial signal transmission/reception (depending on function of card).	Word clock transmission and reception to and from other devices (depending on function of card).	27

System Examples

Large systems using CobraNet

Introduction to the DME64N/24N

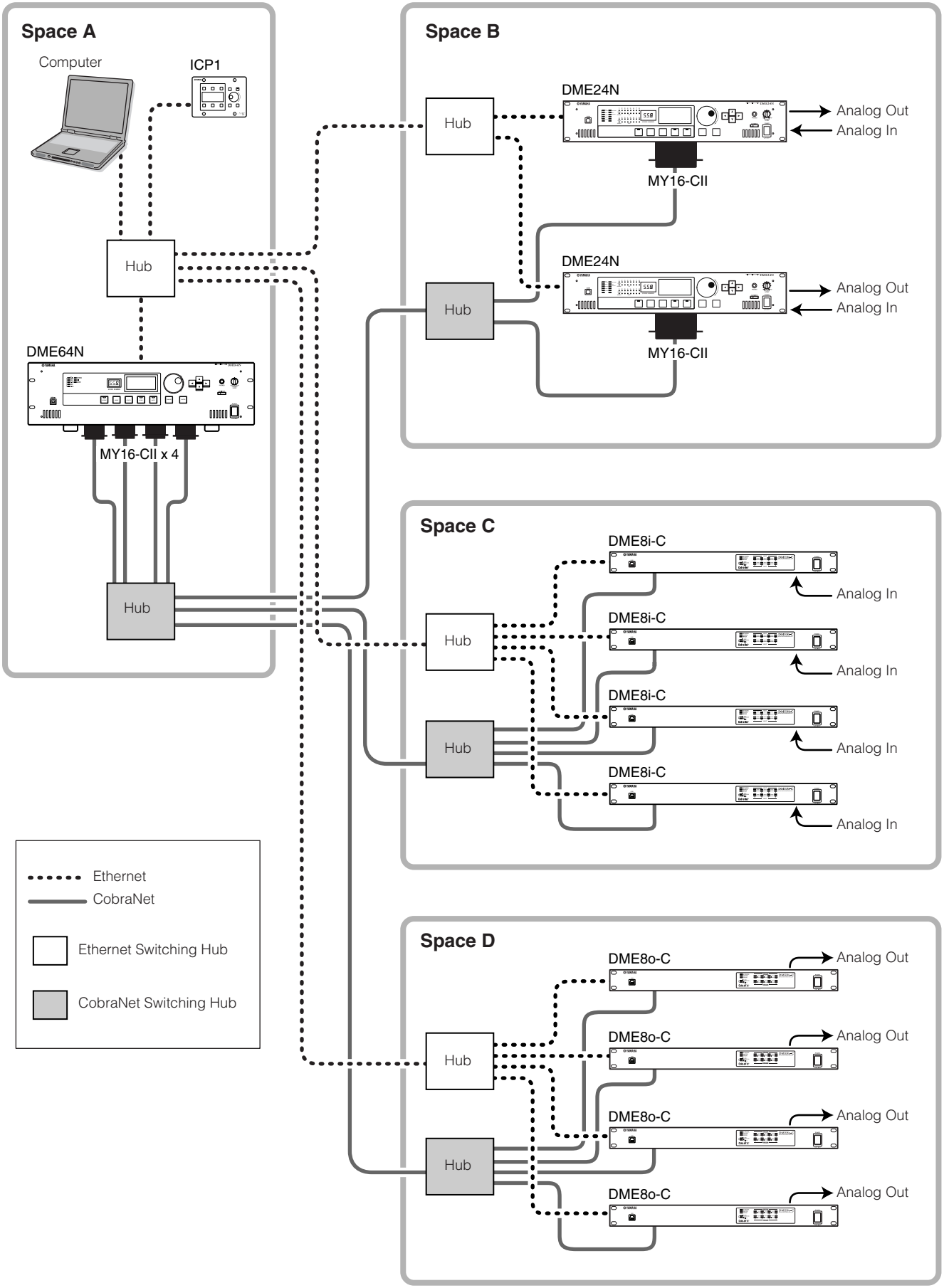

About DME Designer

DME Designer software enables you to integrate, configure, and control the DME series system from a connected computer.

You can build the DME series audio system using graphic blocks in DME Designer that are displayed on the computer monitor.

The DME series settings, configuration, and parameter data are transferred from the computer to the DME series unit via the USB or Ethernet connection.

DME series settings, configuration, and parameter data is sent via USB or Ethernet to the connected DME series unit. After the data is transmitted, you can disconnect the DME series unit from the computer and use it as an independent processor.

You can also connect it to a computer and control it in realtime from DME Designer.

If multiple DME series units are connected in the network, DME Designer enables you to build a configuration that includes those units.

Please download the DME Designer application, driver, DME setup manual, and DME Designer Owner's Manual at the following URL: <http://www.yamahaproaudio.com/>

Refer to the "Connecting to a Computer" (page 22) for more information on connecting a computer to the DME64N/24N. For details on how to install DME Designer and the drivers that are required for connection, refer to the "DME Setup Manual."

Refer to the DME Designer Owner's Manual for setup and operation instructions.

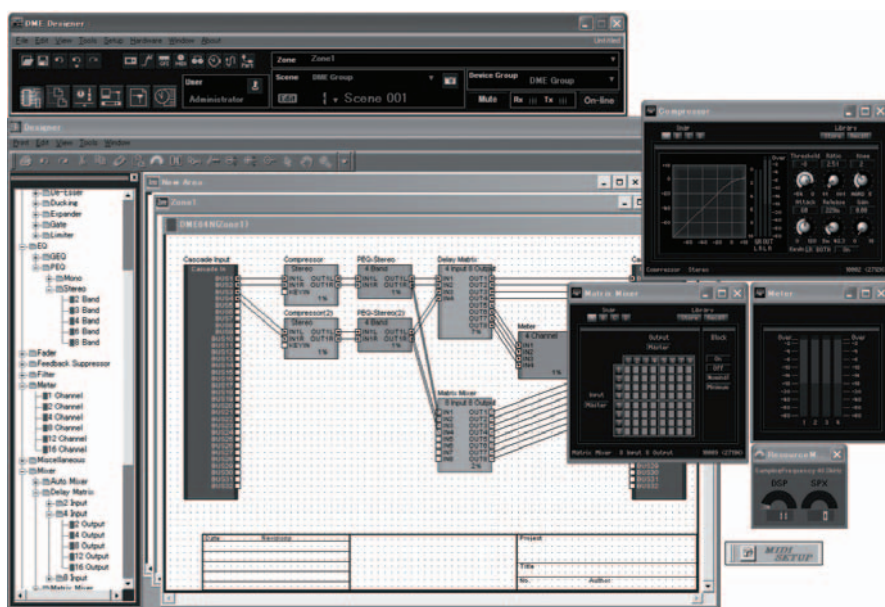

The Controls and Connectors

Front Panel

DME64N

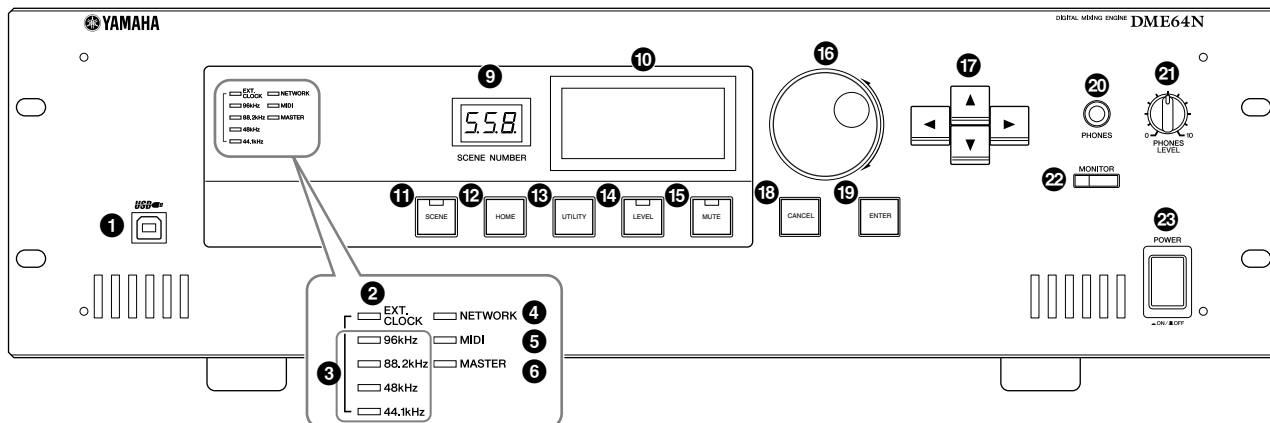

DME24N

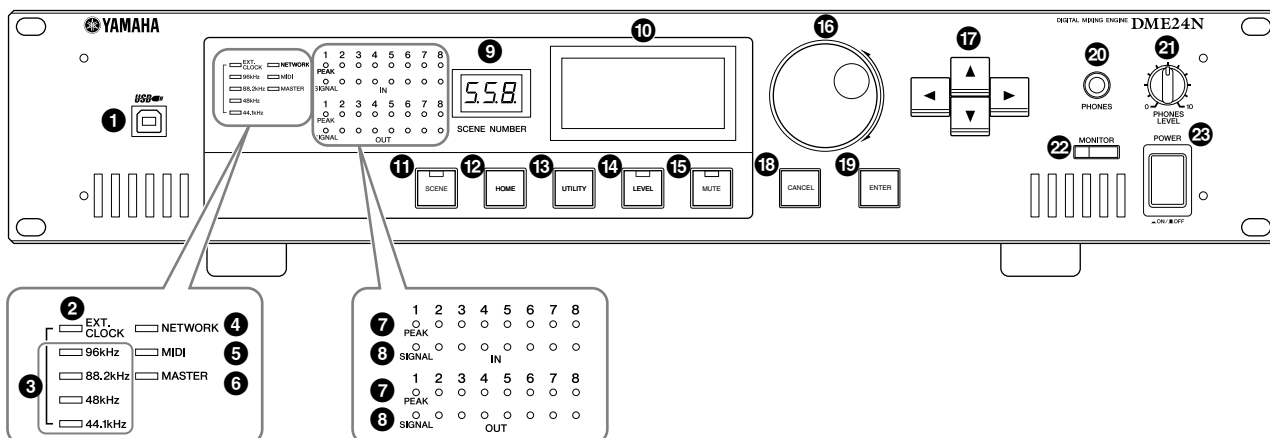

1 [USB] Connector

A computer can be connected here when it is necessary to program or control the device. When a USB connection is to be used, the USB-MIDI driver must be installed on the computer. Refer to the DME Designer Installation Guide for installation instructions.

2 [EXT. CLOCK] Indicator

When a clock signal from an external device is selected, the indicator will light green. If the clock signal is not appropriate the indicator will flash red. The indicator will go out when the internal word clock is selected.

3 [96kHz] [88.2kHz] [48kHz] [44.1kHz] Indicator

Normally, the indicator corresponding to the current word clock frequency will light green. If a problem with the master clock is detected all of these indicators will flash red. 2 seconds after a problem is detected with an external master clock the internal clock will temporarily be selected. When this happens the indicator corresponding to the frequency of the internal clock will light green, and all other indicators will continue to flash red.

4 [NETWORK] Indicator

Lights while data communication is occurring via the [USB], [NETWORK], or [CASCADE] connector. Received data causes the indicator to light in green, while transmitted data causes the indicator to light in orange. If a problem occurs the indicator will light in red.

5 [MIDI] Indicator

Lights while data communication is occurring via the [MIDI] connector. Received data causes the indicator to light green, while transmitted data causes the indicator to light orange. The indicator will light green when reception and transmission occur simultaneously. If a problem occurs the indicator will light red.

6 [MASTER] Indicator

Lights green when the device is operating as the device group master (page 9). The indicator will not light if the device is operating as a device group slave. Refer to page 46 for device group master setup instructions.

7 [PEAK] Indicator (DME24N only)

Light red when a signal on the corresponding built-in analog audio input or output ([IN] and [OUT] connectors) reaches or exceeds -3 dB.

8 [SIGNAL] Indicator (DME24N only)

Light green when a signal with a level greater than -40 dB is present at the built-in analog audio inputs and outputs ([IN] and [OUT] connectors).

NOTE

The DME64N has no built-in analog audio inputs or outputs ([IN] and [OUT] connectors).

9 [SCENE NUMBER] Indicator

Shows the current scene number.

10 Display

Displays scene information and device parameters.

11 [SCENE] Button

Calls the scene recall/store display (page 39). The scene store display will appear if the button is held for longer than 2 seconds (page 40). The indicator will light green while the scene recall or store display is showing.

12 [HOME] Button

Directly recalls the home (main) display. If pressed while the main display is showing the [HOME] button steps through the user-defined parameter display pages (refer to page 38 in this manual).

13 [UTILITY] Button

Calls the output level display. If this button is held for longer than 2 seconds while the main display is showing the utility display will appear. Switches between the Utility display pages if pressed while the Utility display is showing.

14 [LEVEL] Button

Calls the output level setup display (page 39). The indicator will light green.

15 [MUTE] Button

Calls the mute display (page 39). The indicator will light orange when mute is on. The indicator will light green when mute is off and the mute display is showing, and will be off if the mute display is not showing.

16 Dial

Adjusts the value of selected parameters.

17 [◀][▲][▼][▶] Buttons

Move the display cursor in the corresponding directions.

18 [CANCEL] Button

Closes the window on the display.

19 [ENTER] Button

Confirms and enters a value or setting.

20 [PHONES] Jack

A pair of headphones can be plugged in here.

21 [PHONES LEVEL] Control

Adjusts the headphone volume. Even when the control is set to the minimum level, the sound at the headphones is not completely muted.

22 [MONITOR] Button

Calls the monitoring point slot selection display (page 40). When the [ENTER] button is pressed to select a slot, the monitoring point selection display will appear. The spectrum analyzer display will then appear when the [ENTER] button is pressed to select a monitoring point. The indicator will light green while the monitoring slot/point or spectrum analyzer display is showing.

23 [POWER] Switch

Turns mains power to the device on and off.



Even when the power switch is turned off, electricity is still flowing to the product all the minimum level. When you are not using the product for a long time, make sure to unplug the power cord from the wall AC outlet.

Rear Panel

DME64N

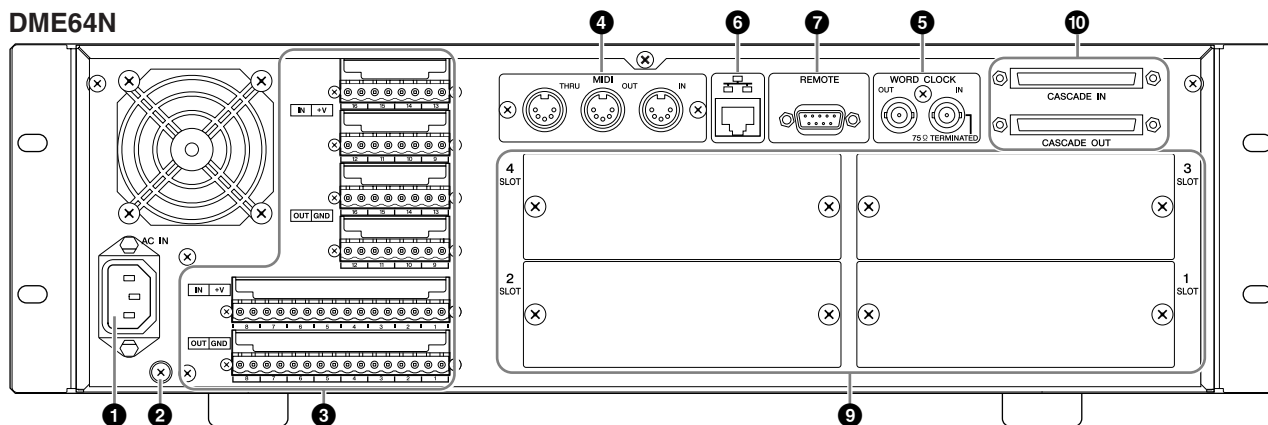

DME24N

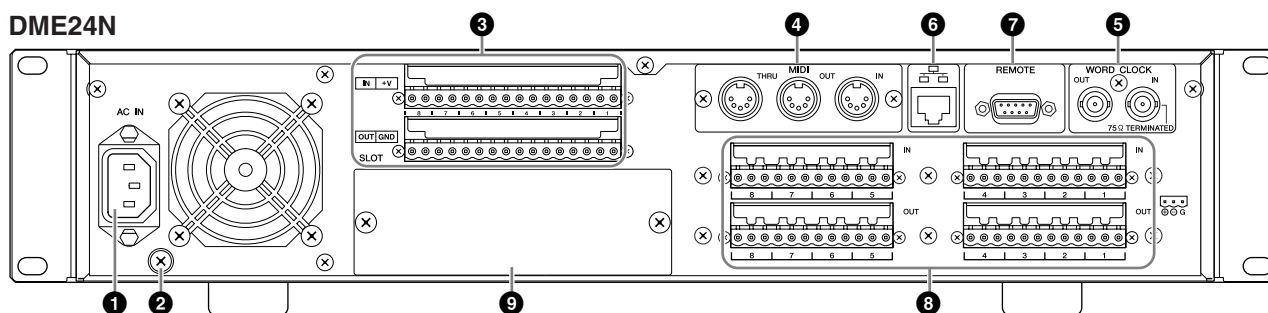

1 [AC IN] Connector

This is the device's three-pronged AC power connector. Connect to the AC mains using the supplied AC power cord. See "Setup" on page 18 for details.

NOTE

Use the supplied AC cord clamp to prevent accidental disconnection of the AC power.

NOTE

When connecting to two-prong type AC mains outlets use the supplied plug adaptor.



Even when the power switch is turned off, electricity is still flowing to the product all the minimum level. When you are not using the product for a long time, make sure to unplug the power cord from the wall AC outlet.

2 Ground Screw

The supplied AC power cable is a 3-wire type, so if the AC outlet used is properly earthed the DME64N/24N will be earthed as well. Hum and interference may be further reduced in some cases by also connecting the earth screw to an earth point.

NOTE

Connect the device to only one ground point. Connecting the device to more than ground point can result in ground loops that can cause increased hum and noise.

3 [GPI] Connector

This Euroblock connector provides access to the unit's GPI (General Purpose Interface) interface for transfer of control signals to and from external equipment. The DME64N provides 16 channels of GPI input and output, while the DME24N provides 8 channels. Each input channel has an IN terminal and a +V terminal. Output channels each have an OUT terminal and a GND terminal. The open voltage at the +V terminal is 5V, while the IN terminal detects voltage changes from 0V - 5V. The OUT terminals output either signal "L" or "H" at a TTL level.

See "GPI Connection ([GPI] Connectors)" on page 33 for connection details.

4 [MIDI IN] [MIDI OUT] [MIDI THRU] Connectors

These are standard MIDI connectors that handle reception and transmission of MIDI data: [MIDI IN] receives MIDI data, [MIDI OUT] transmits MIDI data, and [MIDI THRU] re-transmits MIDI data received at the [MIDI IN] connector. See “MIDI Connection ([MIDI] Connectors)” on page 30 for connection details.

5 [WORD CLOCK IN] [WORD CLOCK OUT] Connectors

These BNC connector receive and transmit word clock from and to external equipment. See “WORD CLOCK Connection ([WORD CLOCK] Connectors)” on page 32 for connection details. Word clock settings are available via the device’s Utility display WCLK page (see page 50 of this document).

6 [NETWORK] Connector

This is a 100Base-TX/10Base-T Ethernet connector for connection to a computer or other DME series units. Normally this connector will be connected to a network hub via an Ethernet “straight” cable. When two DME64N/24N units are to be directly connected a “cross” cable should be used. See “Ethernet Connection ([NETWORK] Connector)” on page 23 for connection details.

NOTE

Use a STP (Shielded Twisted Pair) cable for this connection to prevent electromagnetic interference.

7 [REMOTE] Connector

This 9-pin D-SUB connector allows connection to Yamaha AD824 or AD8HR remote head amplifier or an RS-232C/RS-422 compatible controller such as those from AMX or Crestron. You can also connect a Yamaha PM5D or DM2000 and control the internal head amps of DME24N. Refer to page 28 for connection details.

8 [IN] [OUT] Connectors (DME24N only)

These are balanced Euroblock connectors for analog audio input and output. The analog signal from microphones or line sources such as CD players can be input via the IN connectors, while the OUT connectors can deliver analog output to powered speakers or recording equipment. 48V phantom power can be supplied to the IN connectors (page 53). Refer to page 26 for [IN] and [OUT] connection details.

NOTE

The [IN] and [OUT] connectors each have 24 terminal pins. Each of the eight inputs and outputs uses three pins – hot, cold, and ground. Use the supplied 3-pin Euroblock plugs to connect to the appropriate inputs and outputs.

9 I/O Slots

Optional Yamaha or third-party mini-YGDAI cards can be plugged in here for system expansion. The DME64N has four I/O slots, while the DME24N has one. One expansion card can be plugged into each slot. Refer to “I/O Card Installation” on page 20 for installation details.

10 [CASCADE IN] [CASCADE OUT] Connectors (DME64N only)

This 68-pin D-SUB connector can be connected to the CASCADE connector of other devices via a dedicated cascade cable. The CASCADE connector transmits and receives control, audio, and word clock signals. Refer to “Cascade Connection ([Cascade] Connectors)” on page 31 for connection details.

Setup

Setup Procedure

Follow the steps outlined below to prepare the DME64N/24N for operation.

1. Install any required I/O cards.

Refer to “I/O Card Installation” on page 20 for details.

2. Connect the AC power cord.



Be sure to turn all devices OFF before connecting AC mains power.
Attach the cable clamp to prevent accidental disconnection.

Attaching the cable clamp.

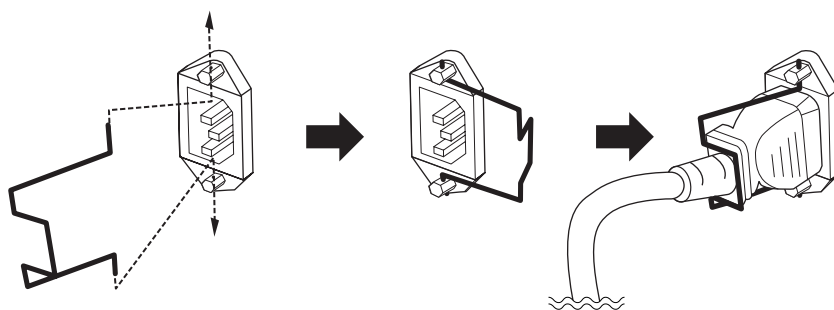

Be sure to properly ground the device to prevent possible electrical shock.

First plug the female-connector end of the AC cord into the [AC IN] socket on the rear panel of the DME64N/24N, then plug the male plug into an appropriate AC mains outlet. Make sure the AC power to be used complies with the conditions marked on the top cover of the device.



Use only the AC power cord supplied with the DME64N/24N. If the supplied cord is lost or damaged and needs to be replaced, contact your Yamaha dealer. The use of an inappropriate replacement can pose a fire and shock hazard! The type of AC power cord provided with the DME64N/24N may be different depending on the country in which it is purchased (a third prong may be provided for grounding purposes). Improper connection of the grounding conductor can create the risk of electrical shock. Do NOT modify the plug provided with the DME64N/24N. If the plug will not fit the outlet, have a proper outlet installed by a qualified electrician. Do not use a plug adapter which defeats the grounding conductor.

Security Cover Mounting

Security cover mounting screw holes (M3 size) are provided on the front panel of the unit. The spacings are 423mm width and 96mm (DME64N) / 52mm (DME24N) height. See “Dimensions” on page 67 for details. A security cover made by the customer or contractor can be attached to the front panel via these mounting holes to prevent accidental operation. Yamaha cannot supply a security cover.

When mounting a cover make sure that the screws used do not go deeper than 15 millimeters into the front panel. Also, to ensure that the cover does not come in contact with the panel controls, leave a space of about 20 millimeters between the front panel and the cover.

3. Install the DME Designer software and necessary drivers on the computer to be used for device group control.

See the “DME Setup Manual” (PDF file) for details.

4. Connect devices.

- Network connection
 - Ethernet connection (page 23)
 - USB connection (page 22)
- Analog connection (page 26)
- External device connection
 - Remote connection (page 28)
 - MIDI connection (page 30)
 - CASCADE connection (page 31)
 - WORD CLOCK connection (page 32)
 - GPI connection (page 33)

5. Turn power to the computer, DME64N/24N, and related devices on. Press the DME64N/24N [POWER] switch to turn it on.



To prevent the initial power-on surge from generating a large noise spike or damaging your speaker system, turn devices on in the following order: audio sources, mixer and/or recorders, and finally power amplifiers. Reverse this order when turning power off.

No information will appear on the display the first time the device is turned on. The appropriate scene and other data must first be transferred to the device from the DME Designer.

Refer to the “DME Setup Manual” (PDF file) for details.

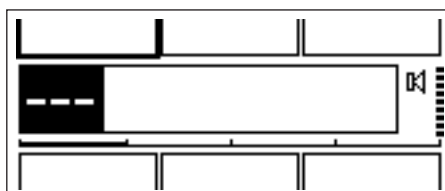

Once the appropriate data has been transferred to the device, the current number and name will appear on the display:

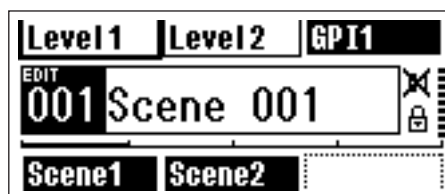

If any scene data has been stored in the DME64N/24N, the current scene and its name will be displayed.

6. Set up the DME64N/24N operation parameters.

See the “Utility Display” section on page 44 for details.

NOTE

The “NET” page settings must be set up as required before using the unit for the first time.

7. Launch the DME Designer application, create configuration and transfer.

DME Designer setup, operation, and data transfer instructions can be found in the DME Designer Manual.

This completes preparation of the DME64N/24N system.

I/O Card Installation

The DME64N has four I/O card slots, and the DME24N has one I/O card slot. The number of audio input channels available on the DME64N/24N can be increased by plugging the appropriate mini-YGDAI I/O card(s) into the available card slot(s).

Compatible I/O Cards

As of April, 2007, Yamaha mini-YGDAI cards that can be used with the DME64N/24N are as follows:

Card Name	Function	Input	Output	No. of Available Cards	
				DME64N	DME24N
MY8-AT	ADAT	8	8	4	1
MY8-TD	TDIF-1	8	8	4	1
MY8-AE	AES/EBU	8	8	4	1
MY4-AD	ANALOG IN	4	–	4	1
MY8-AD	ANALOG IN	8	–	4	1
MY4-DA	ANALOG OUT	–	4	4	1
MY8-AD24	ANALOG IN	8	–	4	1
MY8-AD96	ANALOG IN	8	–	4	1
MY8-DA96	ANALOG OUT	–	8	4	1
MY8-ADDA96	ANALOG IN/OUT	8	8	4	1
MY8-AE96S	AES/EBU	8	8	4	1
MY8-AE96	AES/EBU	8	8	4	1
MY8-AEB	AES/EBU	8	8	4	1
MY16-AT	ADAT	16	16	4	1
MY16-AE	AES/EBU	16	16	4	1
MY16-TD	TDIF-1	16	16	4	1
MY16-C	CobraNet	16	16	4(*)	1
MY16-CII	CobraNet	16	16	4	1

The input/output numbers above apply to 44.1/48kHz operation.

(*)

In order to use three or four MY16-C cards, firmware V1.10 or later will be required.

If the serial number written on the upper surface of your DME64N is shown below, a hardware upgrade is needed.

KK, KL, KM, KN, KO, KP, KX, KY are the third and fourth digits of the serial number.

A fee is charged for the hardware upgrade.

For details, contact Yamaha customer support using the contact information located at the end of the "DME64N/24N Owner's Manual."

For the latest information on what cards can be used with the DME64N/24N, visit the Yamaha Pro Audio website at: <http://www.yamahaproaudio.com/>

I/O Card Installation Procedure

1. Make sure that the DME64N/24N power is OFF.

If the power is on, turn it off.

2. Loosen the two card slot screws and remove the slot cover, as shown in the diagram.

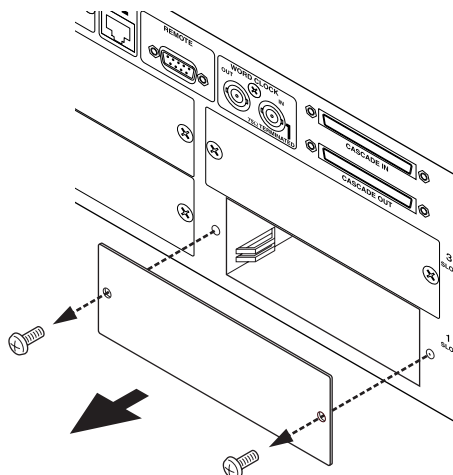

NOTE

The slot cover and screws will need to be re-attached if the I/O card is later removed from the slot, so keep them in a safe place.

3. Slide the I/O card into the slots in the guide rails, as shown in the diagram, and push the card into the slot.

Be sure to push the card all the way back into the slot so that the card contacts make proper contact with the slot connector.

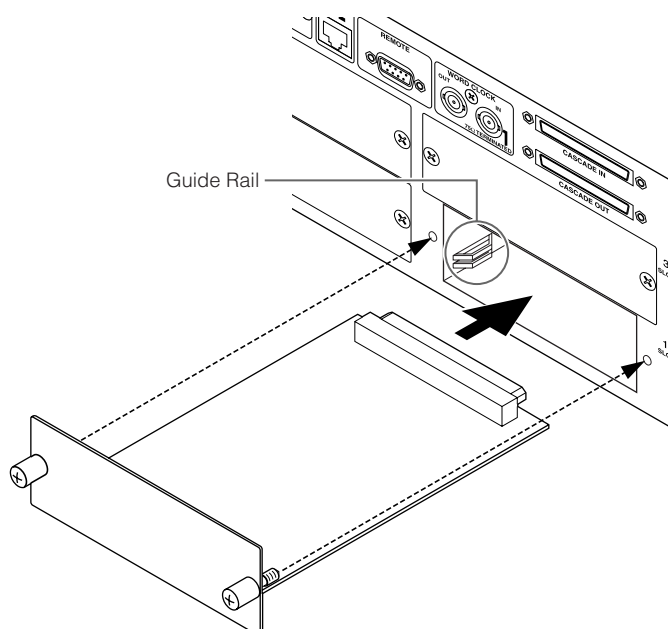

4. Secure the card with the attached screws.



Be sure to tighten the screws securely. If the screws are left loose proper contact may be lost and malfunction of damage may result.

Connecting to a Computer

USB Connection

NOTE

- Refer to the “DME Setup Manual” (PDF file) for details on installing USB-MIDI Driver and DME Designer.
- Make sure that the USB-MIDI Driver’s THRU setting is “OFF.”

USB connections can be used in the following two ways:

- (1) Control the DME64N/24N from DME Designer.
- (2) Connect to any individual DME64N/24N and control that DME64N/24N unit by transmitting MIDI commands from a MIDI sequencer or similar software.

NOTE

- When using a DME64N/24N together with the DME Satellite, you must assign the DME Satellite as the master. The computer on which DME Designer is running can be connected to either the group master or a slave DME series unit.
- The correspondence between the MIDI commands to be received/transmitted and the scene parameters can be set up using DME Designer.
- The USB port being used by DME Designer is not available for use by a MIDI sequencer or other application.

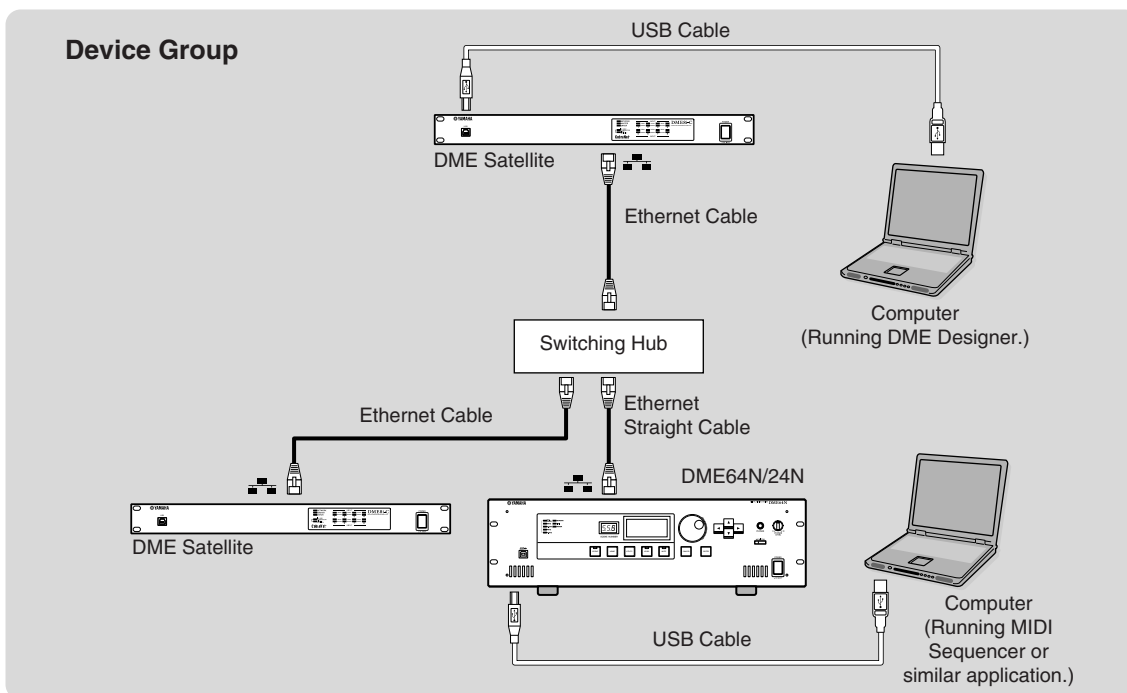

Be sure to follow the procedure below when you make a USB connection with a computer. Otherwise, the computer and/or DME64N/24N may freeze, resulting in damages or loss of data. If the computer or DME64N/24N freezes, turn the power to the DME64N/24N off and then on, then restart the computer.



CAUTION

- Before you connect the DME64N/24N to the computer via USB, cancel the computer’s energy saving mode (such as Suspend, Sleep, or Stand-by mode).
- Before turning on the power to the DME64N/24N, first connect its [USB] connector to the computer’s USB port.
- Before turning the power to the unit on or off, and before connecting or disconnecting the USB cable, take the following actions:
 - Quit all open applications.
 - Make sure that the DME64N/24N is NOT transferring any data.
- Be sure to wait six seconds or more between turning the power to the unit on and then off (or off and then on), or between connecting and disconnecting (or vice versa) the USB cable.

Ethernet Connection ([NETWORK] Connector)

To control the DME64N/24N from the computer via Ethernet, use an Ethernet cable to connect the [NETWORK] connector on the rear panel of the DME64N/24N to the computer, then install DME-N Network Driver.

NOTE

- Refer to the “DME Setup Manual” (PDF file) for details on installing DME-N Network Driver.
- Appropriate IP addresses must first be assigned to all devices connected to an Ethernet network.

Two DME series units directly connected via Ethernet

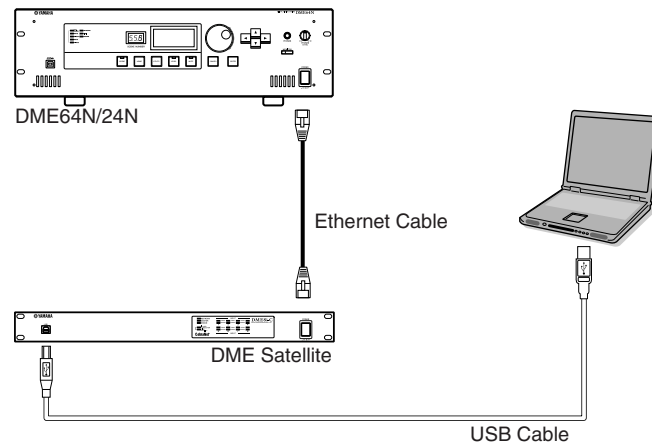

You can connect devices in the same device group directly to each other using Ethernet cables, without connecting them to a switching hub. A cross cable is required to connect between DME64N/24N units.

If one of the units is a DME Satellite then either a cross cable or straight cable can be used since the DME Satellite supports Auto MDI/MDI-X. In this case, set Link Mode on both units to the same setting. Devices in different subnet (different network address) groups can be connected via a router or layer-3 compliant switching hub.

Control from a computer in the same subnet group

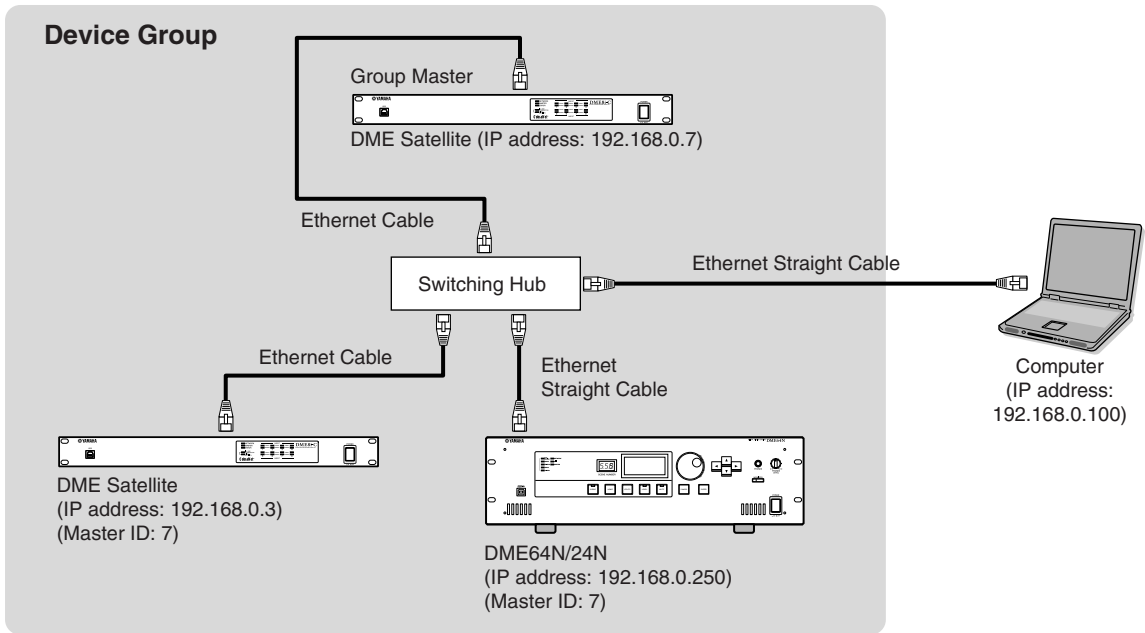

NOTE

- The IP addresses in the diagram are examples.
- Use a switching hub that is compatible with 100Base-TX/10Base-T network speeds. The maximum length of a cable between a switching hub and the DME series is 100 meters. Due to the quality of cables and switching hub performance, however, proper operation at the maximum length cannot be guaranteed in some cases. Use a STP (Shielded Twisted Pair) cable to prevent electromagnetic interference.
- If you are using multiple DME series units, set Link Mode on each unit to the same setting. Yamaha recommends that you select 100Base-TX for the Link Mode setting.

Control from a computer with a different subnet

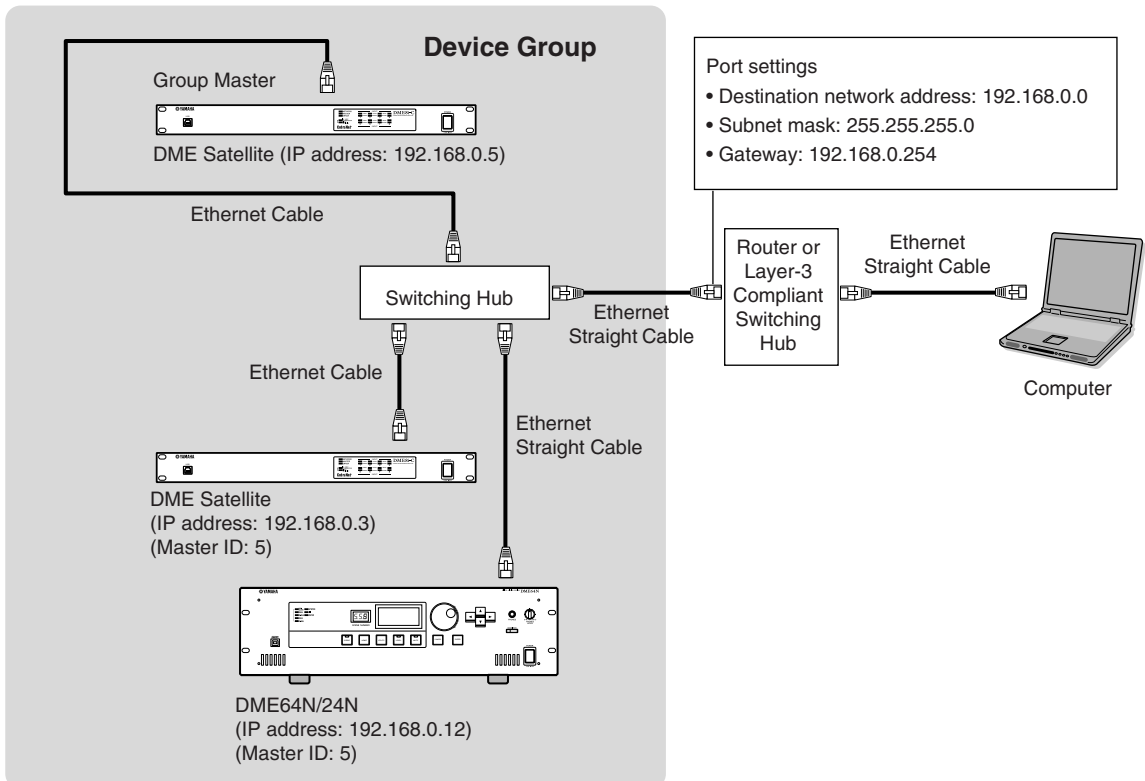

Connecting multiple device groups

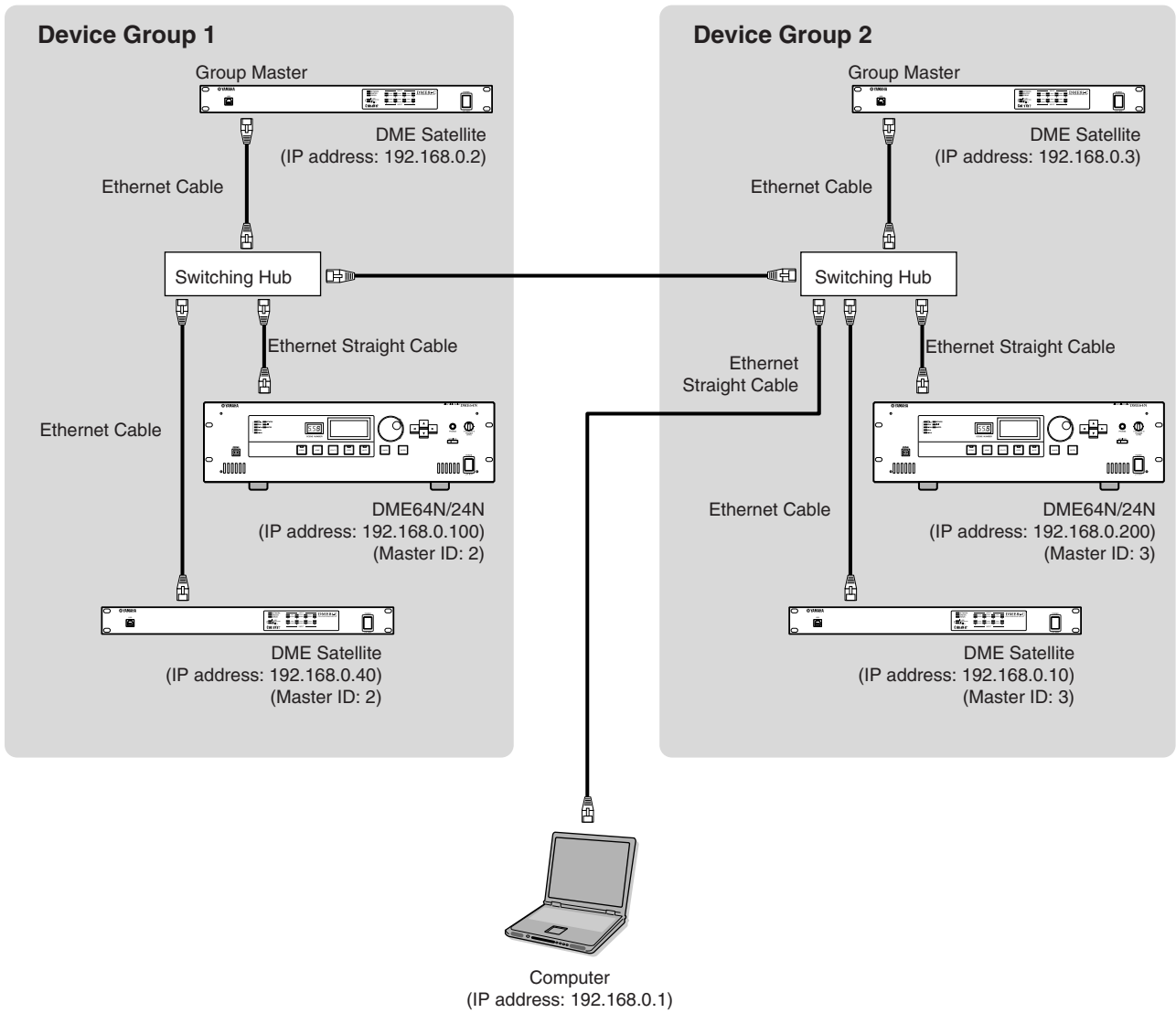

Connecting to a Computer

Audio I/O Connection

Analog Audio Connection ([IN] and [OUT] Connectors) (DME24N only)

The DME24N includes [IN] and [OUT] connectors for 8 channels of analog audio input and output. Wire the supplied Euroblock plugs as shown below. Head amplifier gain and phantom power settings can be made via the Utility display HA page described on page 54 of this manual, or via the DME Designer application.

Euroblock Connection

Please be sure to use the supplied Euroblock plugs. If you lose them, contact your nearest Yamaha dealer.

Cable preparation

- To prepare the cable for attachment to a Euroblock connector, strip the wire as shown in the illustration, and use stranded wire to make connections. With a Euroblock connection, the stranded wire may be prone to breakage because of metal fatigue due to the weight of the cable or due to vibration. When rack-mounting your equipment, use a lacing bar when possible to bundle and fasten the cables.
- If cables will be frequently connected and disconnected, as in the case of a portable installation, we recommend that you use ferrules with insulation sleeves. Use a ferrule whose conductor portion has an external diameter of 1.6 mm or less, and a length of approximately 7 mm (such as the AI0,5-6WH made by the Phoenix Contact corporation).

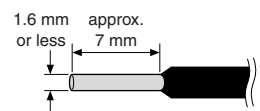
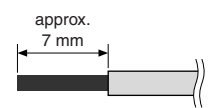

If you use stranded wire, do not tin (plate with solder) the exposed end.

1. Loosen terminal screws.

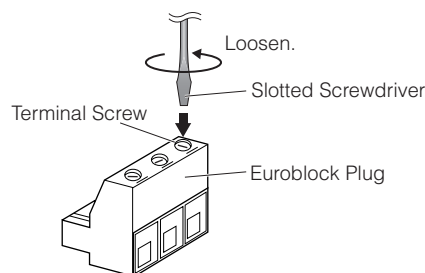

NOTE

A slotted screwdriver with a blade width of about 3 millimeters is recommended.



2. Insert cables.

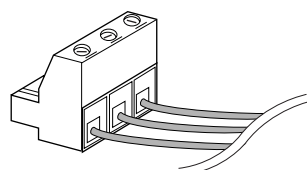

3. Securely tighten terminal screws.

Pull the cables (not too strongly) to confirm that they are securely connected.

4. Plug the Euroblock plug into the panel connector.

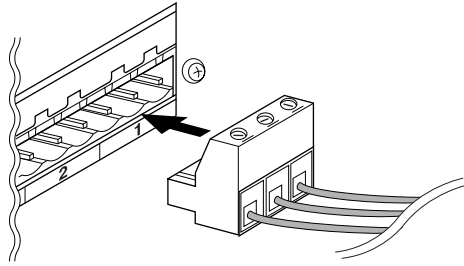

I/O Slots

The DME64N has four I/O card slots, and the DME24N has one I/O card slot. The number of audio input channels available on the DME64N/24N can be increased by plugging the appropriate mini-YGDAI I/O card(s) into the available card slot(s). Some types of cards also provide control and/or word clock transmission and reception functionality.

Refer to “Compatible I/O cards” (page 20) for details on the cards that can be used.

For details on how to install cards, refer to “I/O card Installation Procedure” (page 21).

Connecting to an External Device

Remote Connection ([REMOTE] Connector)

The [REMOTE] connector of the DME64N/24N can be connected to remotely-controllable Yamaha AD8HR or AD824 head amplifiers (pre-amps), digital mixers, or RS-232C compatible controllers (such as those from AMX or Crestron). The [REMOTE] connector also transmits and receives MIDI messages.

Controlling external head amplifiers from the DME64N/24N

You can remotely control the AD8HR or AD824 head amplifier settings from DME Designer. Up to eight AD8HR/AD824 head amplifiers can be connected.

When connecting an AD8HR or AD824 be sure to set the “Utility” screen “MISC” page (see manual page 49) “Remote” parameter to “HA Control (RS422)”. Also, do change to any other setting than “HA Control (RS422)” while the unit is connected. Doing so can damage the unit.

When connecting to a combination of AD8HR and AD824 head amplifiers, be sure to place the AD8HR units closest to the DME64N/24N in the chain, otherwise the AD8HR or AD824 unit(s) may not be properly recognized by the DME64N/24N.

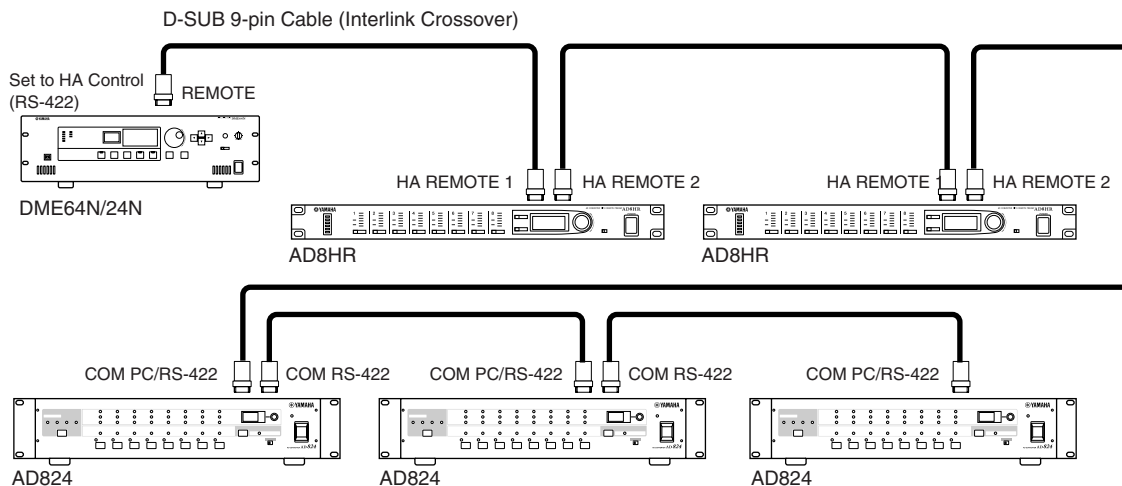

NOTE

Only control signals are transmitted and received via the REMOTE connection. Audio connections must be made separately.

Controlling a DME24N's internal head amps from a digital mixer

The internal head amp settings of a DME24N can be remotely controlled from a digital mixer such as the Yamaha PM5D or DM2000.

Connect the digital mixer to the DME series' [REMOTE] connector, and use an Ethernet cable to make connections between the [NETWORK] connectors of the DME series. From the digital mixer, DME series units can be controlled as an AD8HR.

The gain and the phantom power (+48V) can be controlled.

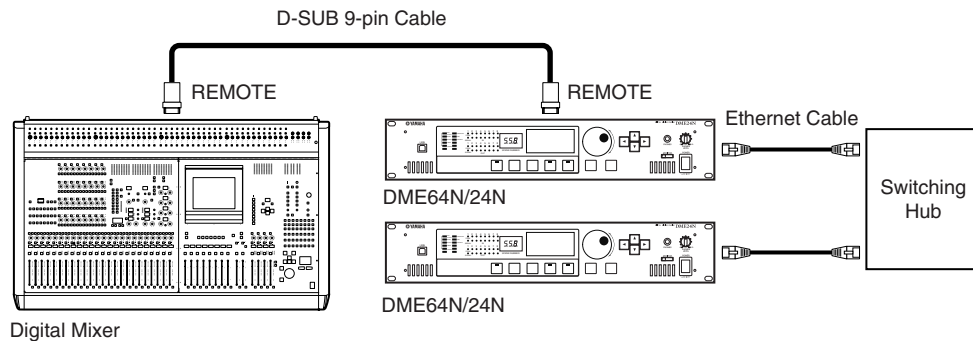

NOTE

- Only one mixer can be connected within each device group.
- The digital mixer can be connected to any DME series unit, whether it is the group master or a slave unit.
- The ID number of the DME series unit being remotely controlled is specified from DME Designer.
- For details on making this setting, refer to the “DME Designer Owner’s Manual.”
- If the connection between DME series units is broken, it will no longer be possible to communicate with DME units of an ID number that follows the disconnected DME.
- The variable range of GAIN differs between the AD8HR and the DME24N. You cannot use the mixer to specify a value that exceeds the variable range of the DME24N.

Controlling the DME64N/24N from an external device

You can remotely control the DME64N/24N from a connected RS-232C or RS-422 compatible controller, such as those from AMX or Crestron.

When connecting a remote controller via RS-232C or RS-422, be sure to set the “Utility” screen “MISC” page (see manual page 49) “Remote” parameter to match the controller being connected. Also, do not change this setting while the unit is connected. Doing so can damage the unit.

NOTE

Refer to “DME Remote Control Protocol Specifications” on the Yamaha web site for more information on communication protocols used to control the DME64N/24N from an external device (such as those from AMX or Crestron).
<http://www.yamahaproaudio.com/>

MIDI Connection ([MIDI] Connectors)

In this case connection is made to the rear-panel [MIDI] connectors. MIDI commands are sent to the DME64N/24N from a MIDI device.

NOTE

Refer to “MIDI Page” on page 51 for MIDI setup details.

NOTE

The DME Designer can be used to set up the system so that scene recall operations and user parameter control can be carried out from connected MIDI devices. Refer to the DME Designer manual for details.

By connecting the [MIDI OUT] terminal of a digital mixer (such as the DM2000) to the [MIDI IN] of the DME64N/24N and making the proper settings on the mixer and the DME64N/24N, you can change scenes by sending program change messages from the mixer.

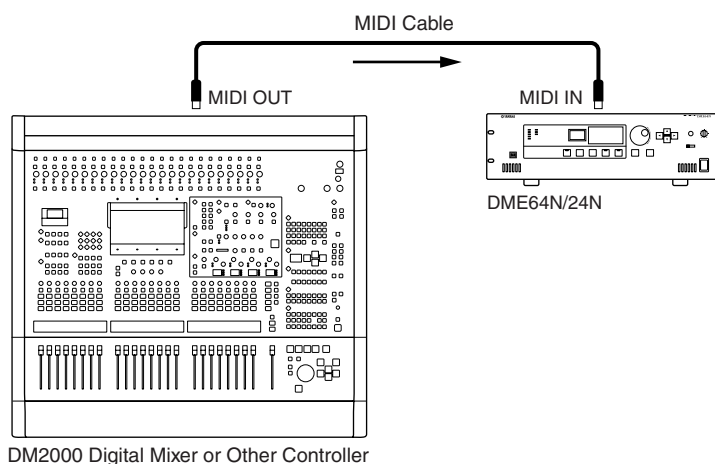

If the [MIDI OUT] connector of the DME64N/24N is connected to the [MIDI IN] connector of an SPX2000 or similar digital effect unit, and if the DME64N/24N and SPX2000 are set up appropriately, DME64N/24N program change operations will cause the corresponding effect to be recalled on the effect unit.

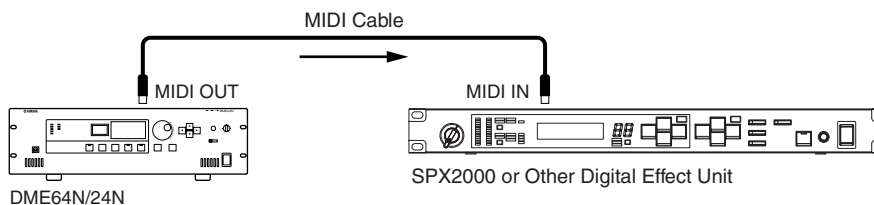

Cascade Connection ([Cascade] Connectors) (DME64N only)

The rear-panel [CASCADE] connector can be connected to the [CASCADE] connector on another DME64N/24N or other compatible device via a dedicated cascade cable for bidirectional transfer of control, audio, and word clock signals. The communication direction automatically switches to unidirectional when connecting to a mixer such as the PM5D, or bidirectional when connecting to another DME64N/24N unit. Up to eight DME64N units can be cascade connected.

In the unidirectional mode the audio signal flow is from the [CASCADE OUT] connector to the [CASCADE IN] connector. For bidirectional communication the data flows in both directions within a single cable, and input on the same channel from other DME64N units is summed (bus sharing). The total number of audio channels that can be connected to a mixer or DME64N/24N unit is 32.

Word clock is continuously output from both the [CASCADE IN] and [CASCADE OUT] connectors, and is received by the corresponding [CASCADE IN] or [CASCADE OUT] connector on the connected device. In all cases the [CASCADE OUT] of one device must be connected to the [CASCADE IN] connector of the other. Do not connect [CASCADE IN] to [CASCADE IN], or [CASCADE OUT] to [CASCADE OUT].

NOTE

Maximum length by the optional dedicated Cascade cables
 Unidirectional Cascade connection: 200m (44.1/48kHz), 100m (88.2/96kHz)
 Bidirectional Cascade connection: 100m (44.1/48kHz), 30m (88.2/96kHz)

Cascade Connection Example

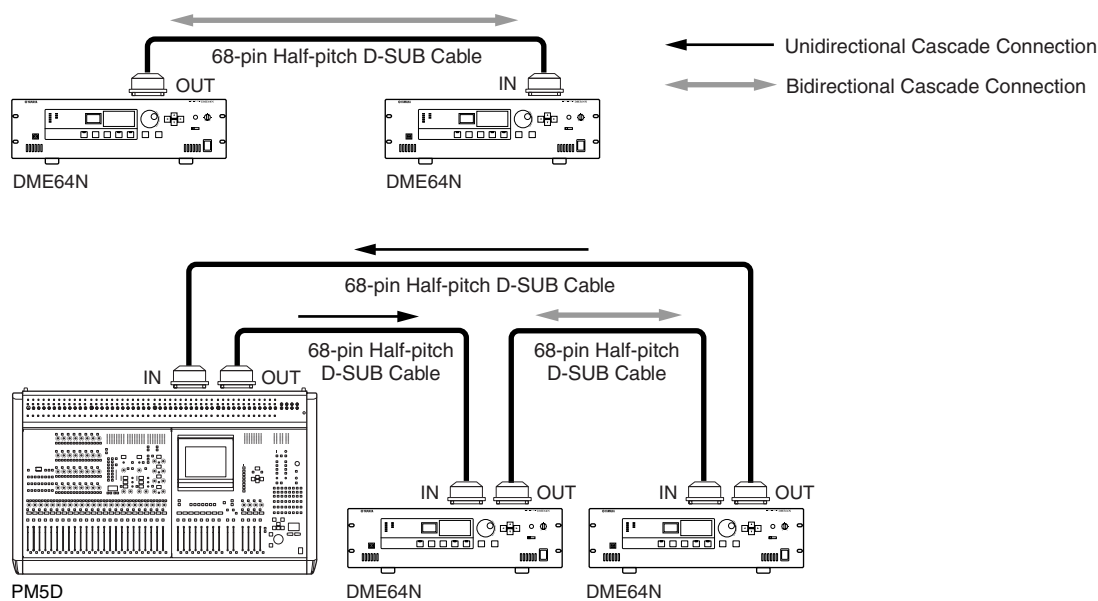

NOTE

Never create a full cascade loop using only DME64N units!

NOTE

It is also possible to remotely control DME series units from the PM5D via a CASCADE connection. In such cases assign the nearest DME64N unit to the PM5D as the device group master. When using a DME64N/24N together with the DME Satellite, you must assign the DME Satellite as the master. Another method of remotely controlling a DME series from a PM5D is via CobraNet connections to MY16-C or MY16-CII cards.

All DME series units to be controlled from the PM5D must be in the same device group, and the host address of the device group master must be set to "2." However, if the PM5D is version 2.20 or higher and the DME Satellite is version 3.07 or higher, you can set the parameter to any number.

For information on the PM5D DME CONTROL function refer to the PM5D/PM5D-RH Owner's Manual or to the "Cascade Setup Guide" available at the Yamaha website.
<http://www.yamahaproaudio.com/>

Connecting to an External Device

WORD CLOCK Connection ([WORD CLOCK] Connectors)

Word clock signals are transferred to and from external devices via the [WORD CLOCK IN] and [WORD CLOCK OUT] connectors. The [WORD CLOCK OUT] connector can be used to supply the DME64N/24N word clock to external equipment. Word clock is continuously output by the DME64N/24N during normal operation. The word clock signal from an external device can be received via the [WORD CLOCK IN] connector.

NOTE

Word clock can also be received and transmitted via a mini-YGDAI card installed in an I/O slot, or the [CASCADE IN] and [CASCADE OUT] connectors. It is necessary to specify whether the DME64N/24N will use the internal word clock or an external word clock for synchronization. Refer to the Utility display WCLK page described on page 50 of this manual for details.

NOTE

A device transmitting the word clock signal that will be used by other devices for synchronization is the “word clock master,” while devices received the word clock are “word clock slaves.”

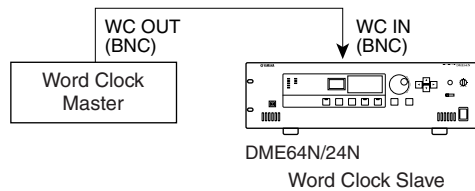

To distribute the word clock signal from one device to multiple slave devices, either a word clock distribution box or daisy-chained connection can be used.

Distribution Box Connection

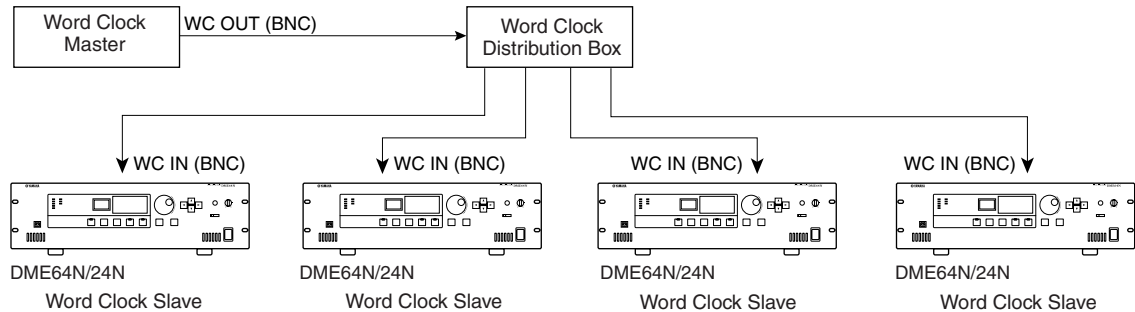

Daisy Chain Connection

NOTE

This method is not recommended for large systems.

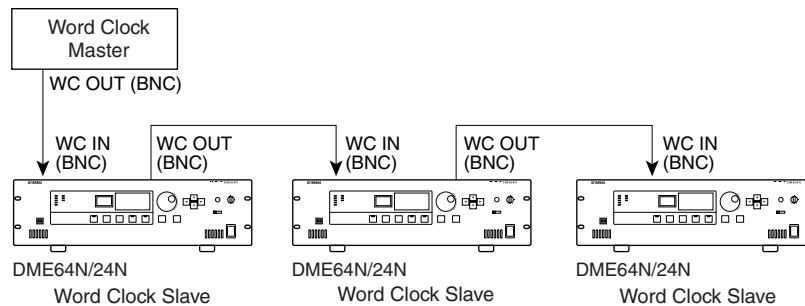

GPI Connection ([GPI] Connectors)

GPI (General Purpose Interface) device (GPI controller, etc.) can be connected to the rear-panel [GPI] connectors. Using GPI a variety of control signals can be transferred between the DME64N/24N and external controllers or other devices. The optional CP4SW, CP4SF, and CP1SF control panels are also connected via GPI.

NOTE

For more information on the CP4SW, CP4SF, and CP1SF control panels refer to “CP4SW, CP4SF, and CP1SF” in the Appendix of this manual (page 53).

The DME64N provides 16 channels of GPI input and output, and the DME24N provides 8 channels. Each channel has an IN terminal, a +V terminal, an OUT terminal and a GND terminal. The +V terminals have an open-terminal voltage of 5 volts. The IN terminals can detect a full range of input voltages from 0V through 5V, while the OUT terminals output either signal “L” or “H” at a TTL level.

The parameters for each GPI input and output are assigned via the DME Designer application.

NOTE

The DME Designer can be used to set up the system so that scene recall operations and user parameter control can be carried out from connected GPI control devices. Refer to the DME Designer manual for details.

Euroblock connectors are used for all GPI input and output connections. Euroblock connection methods are described in “Euroblock Connection” on page 26 in this manual.

Example: Controlling the DME64N/24N from a switch.

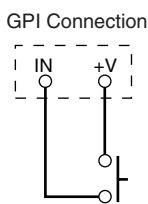

Example: Controlling the DME64N/24N via a 10k ohm linear taper potentiometer.

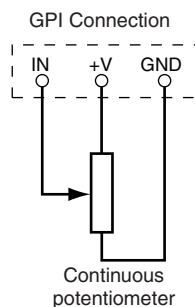

Example: Lighting external LED indicators from the DME64N/24N.

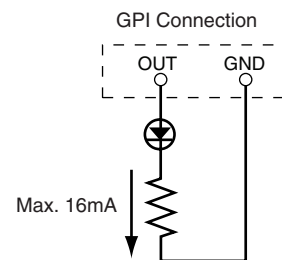

Make sure that the current between the OUT and GND [GPI] connectors is less than 16mA.

NOTE

GPI connector calibration procedure is described on page 53 of this manual, in the Utility display GPI page.

Panel Operation and Displays

Basic Operation

By pressing the panel keys it is possible to select the DME64N/24N Main display, Utility display, and Parameter Edit displays that allow individual settings to be edited and changed. refer to the pages listed below for more detailed information about each display.

[HOME] key → Main Display (page 35)

The Main display can be directly recalled from any display other than the Main display by pressing the [HOME] key. The Main display shows the current scene information



[HOME] key → User Defined Button Page Selection (page 38)

Pressing the [HOME] key while the Main display is shown sequentially selects the four User Defined Button pages.

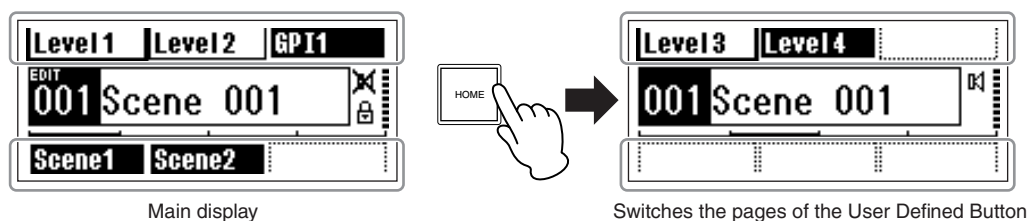

[MUTE] key → Mute Display (page 39)

[LEVEL] key → Output Level Display (page 39)

[SCENE] key → Scene Recall Display (page 39)/Scene Store Display (page 40)

These keys can be pressed from the Main or Utility displays to directly call the related parameter edit displays.

[MONITOR] key → Monitor Point Selection Display (page 40)

This function is useful for level monitoring. When the key is pressed the monitor point selection display will appear, and the spectrum analyzer display will appear when a selection has been made.

[UTILITY] key → Utility Display (page 44)

The Utility display appears when the [UTILITY] key is pressed for longer than two seconds while the Main display is showing.

The Utility display includes a number of pages that can be selected in sequence by repeatedly pressing the [UTILITY] key.

Main Display

The Main display will appear in a few seconds after the power is turned on. The Main display shows information about the current scene.

NOTE

Nothing will appear on the display if no scene data is stored in the DME64N/24N scene memory (this is the case when the unit is initially shipped, for example).

Up to 24 parameters can be accessed from the DME64N/24N or ICP1 control panel for each scene. Six parameters are shown on the Main display at a time.

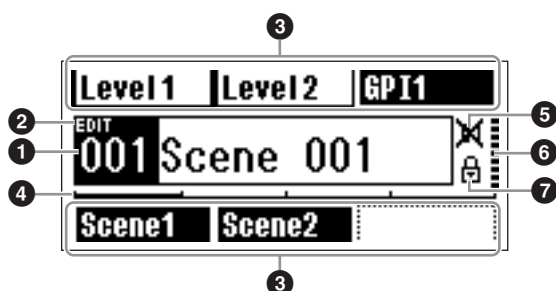

1 Scene Information

The current scene number and name. Scene names can be entered by using the DME Designer application. A maximum of 12 one-byte (Roman) characters can be displayed in a scene name. When “two-byte” characters are to be used for languages such as Japanese, the total number of displayable characters is reduced accordingly. When the power is turned on the last scene selected before the power was turned off is automatically recalled.

2 Edit Indicator

If a parameter is changed after recalling a scene, a dot will appear in the scene number indicator, and “EDIT” will appear in the display.

3 User Defined Button Names

Displays the User Defined Button. The buttons are specified by using the DME Designer application. “No Assign” settings in DME Designer are displayed as dotted lines. When [Parameter Value Edit] is selected the display will be a solid line. When [Direct Parameter Value], [Scene Change], [GPI Out], or [Play Wav File] are selected, the display will be inverted.

A maximum of 24 buttons can be made available for user control, but only six buttons can be shown in any one display page. Press the [HOME] key to switch to other available button pages. A maximum of 8 one-byte

(Roman) characters can be displayed in a button name. When “two-byte” characters are to be used for languages such as Japanese, the total number of displayable characters is reduced accordingly.

Buttons are selected for editing by using the cursor keys – [◀] [▲] [▼] [▶] – to select the button, and then pressing [ENTER].

NOTE

User Defined Button settings are common to the device group.

4 Page Scroll Bar

The scroll bar provides an indication of which parameter page is currently being displayed. 4 pages are available, and the scroll bar moves one position to the right each time the [HOME] key is pressed and a new page of parameters is selected, and then back to the leftmost position after the rightmost position has been reached.

NOTE

Scroll bar operation is independent for each DME64N/DME24N unit, and is not linked within a device group.

5 Mute Indicator

Shows the current mute ON/OFF status.

 : Mute ON

 : Mute OFF

6 Output Level Indicator

Displays the current output level in 10 increments. The longer the “bar,” the higher the output level.

7 Panel Lock Icon

This icon appears when the panel lock function is turned ON.

 : Panel Lock ON (Panel controls locked)

Panel Lock

The panel controls can be “locked” to prevent accidental mis-operation.

To activate the panel lock function simultaneously press and hold the [HOME] and [ENTER] keys for longer than 2 seconds.

The panel lock icon will appear on the Main display when the panel is locked.

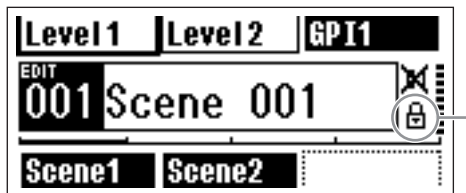

Panel lock icon

Panel Lock can be disengaged by pressing the [CANCEL] key for longer than 2 seconds.

NOTE

The panel lock function can be set up to lock just the panel keys (“Key Only”), or the panel keys and GPI control (“Key+GPI”). You can also select whether or not the panel lock function is automatically engaged when the unit is initially turned on. This selection can be made via the Utility display “Lock” page (refer to the page 48).

Parameter Edit Displays

Parameter Edit displays will appear when the [SCENE], [MUTE], [MONITOR] or other key is pressed to allow scene changes, level adjustment, and other settings to be edited as required. Parameter Edit displays are also used to edit utility parameters.

In most cases the desired parameter edit page can be accessed by selecting the item you want to edit in the appropriate display by using the cursor [◀], [▲], [▼], and [▶] keys, and then pressing the [ENTER] key.

There are basically three types of parameters that can be accessed via a Parameter Edit display:

- Numeric values
- Lists
- ON/OFF switches

Numeric Parameters

Numeric parameters can be edited in a number of ways, and depending on the parameter a fader, knob, or minimum and maximum values may appear to the left of the numeric value.

A Numeric Value with a fader

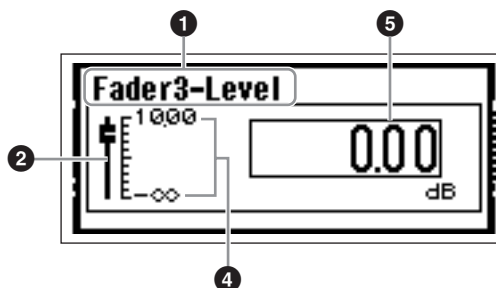

A Numeric Value with a Knob

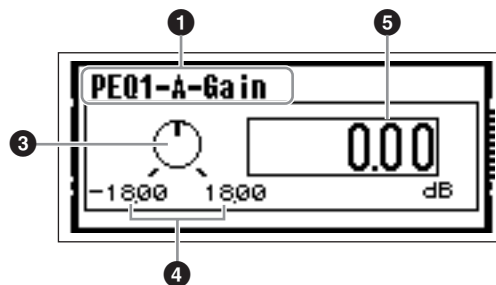

- 1 Name of parameter selected for editing
- 2 Fader
- 3 Knob
- 4 Minimum and maximum values
- 5 Current value

Some Parameter Edit displays have just one numeric parameter, while other may have two or more.

Parameter Edit Display with One Numeric Parameter

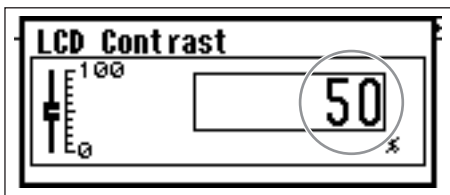

1. Numeric values can be changed by rotating the dial. Dial rotation produces an immediate, corresponding change in the selected value.

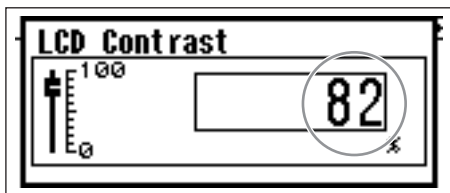
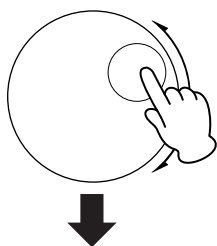

2. Press the [ENTER] key to close the Parameter Edit display after the value(s) have been edited as required.

Parameter Edit Display with Multiple Numeric Parameters



1. Use the cursor keys – [◀] [▲] [▼] [▶] – to select the value to be edited.

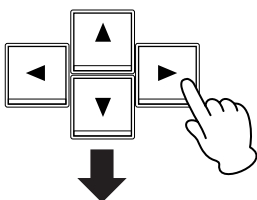

2. Rotate the dial to edit the value as required.

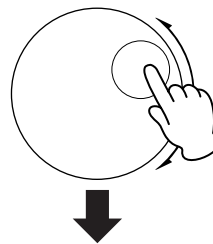

3. Repeat step 1 to select the next value to be edited, use the dial to edit as required, and repeat until all values have been edited as required.

4. When all values have been edited, press the [ENTER] key. A confirmation window will appear: press [ENTER] one more time to confirm the edits and close the window.

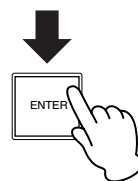
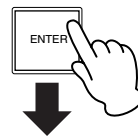

NOTE

You can close the window without changing any values by pressing the [CANCEL] key rather than the [ENTER] key.

List Parameters

List parameters allow you to make one selection from a list of possibilities.

Rotate the dial to scroll up or down the list. In some cases the centermost item on the display will be always highlighted as the list is scrolled, and in others the same item will remain highlight as the list is scrolled up or down.

List Parameter with Center Item Always Highlighted

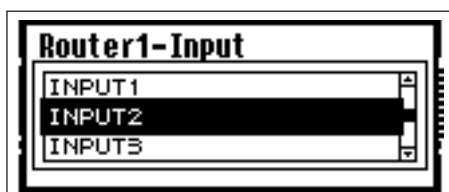

1. Use the dial to scroll up or down the list.

As you scroll the centermost item on the display will be highlighted.

2. Press the [ENTER] key to select the highlighted item and close the window.

List Parameter with Scrolling Highlight

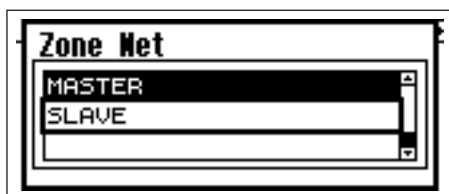

1. Use the dial to scroll up or down the list.

As you scroll the highlighted selection will remain highlighted, and will scroll up or down with the list.

2. Press the [ENTER] key to highlight the centermost item on the display.

NOTE

In some cases a confirmation dialog will appear when the [ENTER] key is pressed. If this occurs press the [ENTER] key a second time to continue.

3. Press the [ENTER] key to select the highlighted item and close the window.

ON/OFF Parameters

Parameters that are either ON or OFF are edited via this type of display (e.g., Mute Parameter Edit display in “Mute Switching” on page 39).

1. Rotate the dial clockwise to select ON, or counterclockwise to select OFF.
2. Press enter to confirm the selection and close the window.

Parameter Edit displays will also appear when the [SCENE], [MUTE], [MONITOR] or other key is pressed.

These allow scene changes, level adjustment, and other settings to be edited as required.

Editing User Defined Button

1. If the Main display is not showing, press the [HOME] key to recall it.
2. Press the [HOME] key until the page containing the parameter to be edited appears.
3. Use the [◀][▲][▼][▶] keys select the parameter to be edited.
4. Press the [ENTER] key.

The Parameter Edit display for the selected User Defined Button will appear.

NOTE

User Defined Button can be of all three types: numeric, list, and ON/OFF.

NOTE

When editing from an ICP1 control panel, the [F1] ~ [F6] keys are used for button selection.

5. Edit the User Defined Button as required.

Refer to “Parameter Edit Displays” on page 36 for editing procedures.

NOTE

Any changed User Defined Button values will be lost if the power is turned off or if scenes are changed. However, if the Last.Mem.Resume setting is ON, the setting will be preserved even when the power is turned off. To preserve the changed values, store the scene data.

Mute Switching

Turns the DME64N/24N output mute function ON or OFF.

1. Press the [MUTE] key.

The Mute Parameter Edit display will appear.

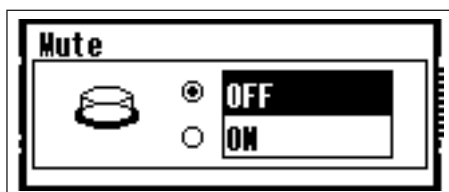

2. Select Mute ON or OFF.

The mute function is turned on or off as described in “ON/OFF Parameters” on page 38.

NOTE

To access this function from the ICP1 control panel, hold the [F6] key for longer than 2 seconds.

NOTE

All outputs in the device group, including the [PHONES] jack, are muted.

Output Level Control

Adjust the output level of the DME64N/24N.

NOTE

Output level settings apply individually to each DME64N/24N unit. There is no overall device group setting. This function cannot be accessed from the ICP1 control panel.

1. Press the [LEVEL] key.

The “Output Level” Parameter Edit display will appear.

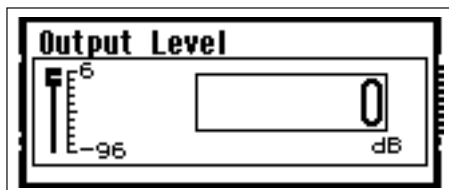

2. Adjust the numeric output level parameter as required.

The Output Level parameter is adjusted as described in “Numeric Parameters” on page 36. The graphic fader provides a visual indication of the current output level setting.

Scene Recall

This procedure recalls a new scene (refer to page 10).

NOTE

The same procedure is used for scene recall from an ICP1 control panel.

1. Press the [SCENE] key.

The Scene Recall display will appear.

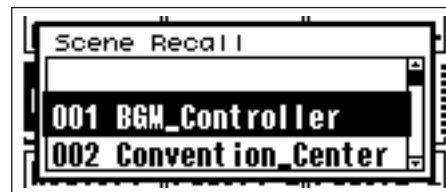

2. Select a new scene.

Scenes are selected as described in the “List Parameters” section on page 38.



3. Press the [ENTER] key.

A confirmation window will appear.



4. Press the [ENTER] key again.

The new scene will be selected.

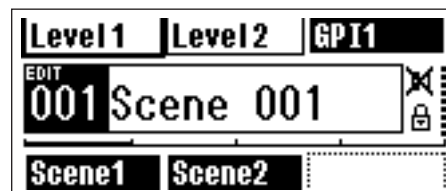

Don't turn the power off during a scene recall operation. Doing so can cause corruption of the current scene data.

NOTE

Scenes can also be changed from a computer or GPI/MIDI controller connected to the device.
 The DME Designer application is used to make scene changes from a computer. If a GPI/MIDI controller is to be used for changes it must be initially set up for scene change control by using the DME Designer.

NOTE

If head amplifier parameters are included in the recalled scene data, the head amplifier settings will be changed accordingly.

Scene Store

Stores the current scene data for later recall.

NOTE

This function can be accessed in the same way from the ICP1.

1. Press the [SCENE] key for longer than 2 seconds.

A confirmation window will appear on the display.



2. Press the [ENTER] key.

This stores the scene data in the current scene memory.

NOTE

Press the [CANCEL] key if you want to abort the scene store operation.

NOTE

If head amplifier settings are included in the scene the Utility display HA page settings are also stored. If head amplifier settings are not included in the scene, the HA page settings are stored as head amplifier startup settings.

NOTE

Any parameter values changed by GPI/MIDI controllers will be lost if the power is turned off or if scenes are changed. To preserve the changed values, store the scene data.

Monitoring

The monitor functions allow you to monitor the audio signal at the inputs or outputs of I/O slots, points between components, and other critical monitoring points.

NOTE

User-defined monitoring functions, such as monitoring at points between components, must specified via the DME Designer application.

NOTE

These functions cannot be accessed from the ICP1.

1. Press the [MONITOR] key.

The slots available for monitoring will be shown in the parameter list.

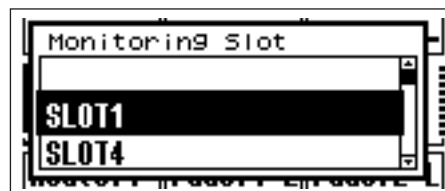

2. Select the desired monitor source from the list.

List selections are made as described in the "List Parameters" section on page 38.

The following five position types can be selected:

- 1 Slot input/output terminal
- 2 CASCADE input/output terminal (DME64N only)
- 3 IN terminal (DME24N only)
- 4 OUT terminal (DME24N only)
- 5 User Defined

By connecting 1 through 4 in DME Designer, you will be able to select the input/output terminal.

You will be able to select 5 by editing the Monitoring Point List in DME Designer.

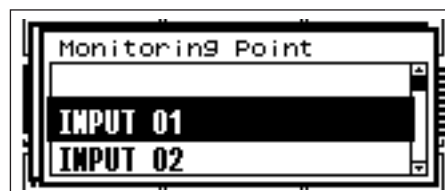

3. Select the desired monitor point from the list.

The audio signal from the selected monitoring point will be output via the PHONES jack and the [MONITOR] indicator lights up.

NOTE

Press the [CANCEL] key to move back to the previous edit display.

NOTE

When the monitoring function is set to ON ([MONITOR] indicator lit steadily), you can turn it OFF by pressing the [MONITOR] button.

Probe Monitor Functions

The Probe Monitor function allows monitoring points to be selected from the DME Designer application. For details, see the “DME Designer Owner’s Manual.”

When the Probe Monitor function is used the monitoring point will change and the [MONITOR] indicator will flash.

NOTE

The monitoring point selected in the DME64N/24N is disabled.

Spectrum Display

The monitor functions also provide spectrum analyzer type level display of the signal at the selected monitor point.

NOTE

Spectrum display is not available on the ICP1 control panel.

Procedure

1. Select the monitor point for which you want to see a spectrum display from the list.

2. Press the [ENTER] key.

A spectrum display of the audio signal at the selected monitor point will appear.

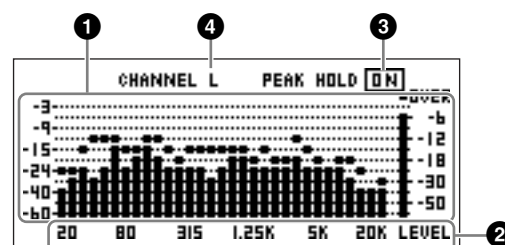

1 Frequency

These are the separate frequency bands displayed.

2 Band Output Level

Signal level is displayed independently in 31 separate frequency bands. Output level is displayed in 12 steps.

3 Peak Hold

When the peak hold function is ON, peak levels since the current monitor point was selected are held indefinitely. Peak levels are cleared after one second when peak hold is OFF.

To turn the peak hold function ON or OFF, move the cursor to the PEAK HOLD ON/OFF setting and press the [ENTER] key to alternately turn it ON or OFF.

4 L/R Select

Indicates when the spectrum display is for the left or right channel. The same spectrum display will be shown for the L and R channels of all monitor points other than user-defined points specified via the DME Designer application.

To switch between the L and R displays move the cursor to the CHANNEL L/R setting and press the [ENTER] key to alternately select L or R.

NOTE

The fall rate of the meters can be set up via the Utility display "Disp" page.

Level Meter Display

Individually displays the input/output level for each channel.

NOTE

Level display is not available on the ICP1 control panel.

1. Make sure that the Main display is showing.

If the Main display is not showing, press the [CANCEL] to return.

2. Press the [UTILITY] key.

The level meter display will appear.

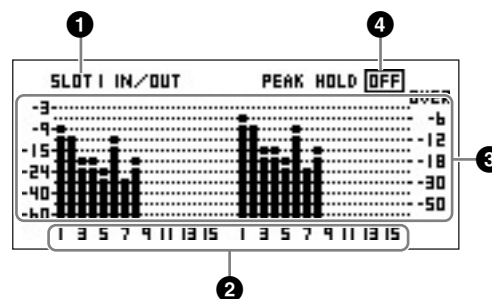
**1 Level Display Slot**

Select from [SLOT1] ~ [SLOT4], [AD/DA], [CASCADE IN] or [CASCADE OUT].

NOTE

[SLOT2] ~ [SLOT4] and [CASCADE IN], [CASCADE OUT] are only available on the DME64N, while [AD/DA] is only available on the DME24N.

2 Channel Number

A maximum of 32 [CASCADE IN]/[CASCADE OUT] channels can be displayed, while for other channels a maximum of 16 can be displayed.

3 Input/Output Level Display

Shows the levels at the individual inputs and outputs.

4 Peak Hold

When the peak hold function is set to ON, peak levels are held indefinitely.

Peak levels are cleared after one second when peak hold is set to OFF.

To turn the peak hold function ON or OFF, move the cursor to the PEAK HOLD ON/OFF setting and press the [ENTER] key to alternately turn it ON or OFF.

Initializing the DME64N/ DME24N

The DME64N/DME24N and ICP1 internal memories can be initialized as follows.

Begin with the power turned off. Turn the power on while holding the [SCENE] and [ENTER] buttons, and continue to hold those buttons until the Yamaha logo appears.

The initialization screen will appear, allowing you to choose one of the following three options.

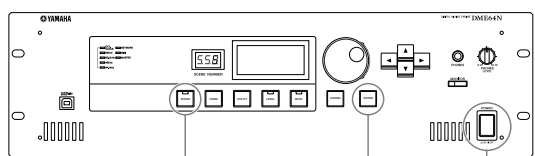

1. Holding down the [SCENE] and [ENTER] buttons

2. Press the [POWER] button

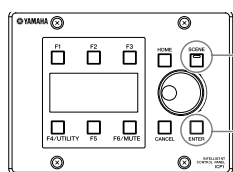

Plug the PA-300 AC adaptor while holding down the [SCENE] and [ENTER] buttons

01. Initialize DME:

All scenes, preset parameter settings and WAVE files except components and files saved via the File Storage function will be deleted. All UTILITY settings are reset to their default values.

02. Delete All Data:

All internally-stored components, scenes, preset parameters, wave files, and files stored using the File Storage function are erased. All UTILITY settings are reset to their default values. Use this problem when a problem occurs with the data stored in the device. After initialization all necessary components will need to be resent from the DME Designer application.

03. ==> Exit Diag Mode:

Exits from the initialization screen and restarts the unit.

Do not turn off the power during initialization. Doing so can damage the device.

Utility Displays

Most basic DME64N/24N functions can be accessed via the Utility Display.

Items accessible via the Utility display

Page	Item	Description	Manual Page
Info		Current status and settings for the devices basic parameters.	Page 46
	Label	Name display.	
	Version	The device's current version number.	
	Date	Current status and setup for the internal calendar/clock.	
	Battery	Shows the status of the internal battery.	
Net		Current status and settings for the Ethernet network.	Page 47
	MASTER/SLAVE	Displays current status and determines whether the device is device group master or not.	
	IP Adr.	Current status and setup for the device's IP address.	
	Master ID	Displays and sets the device group master host address.	
	Link Mode	Current status and setup for the [NETWORK] connector.	
	MAC Adr.	Displays the device's MAC address.	
Disp		Current status and setup for the display mode, etc.	Page 47
	LCD Contrast	Current status and setup for display panel contrast.	
	LCD Backlight	Current status and setup for the display panel backlight.	
	Meter Fall Time	Current status and setup for meter fall time.	
Lock		Current status and setup for panel lock and related functions.	Page 48
	Utility	Current status and setup for the Utility display settings.	
	Panel Lock Boot	Current status and setup for the DME64N/24N's power-on panel lock status.	
	Panel Lock Target	Current status and setup for the panel lock target.	
	User Defined Lock	Panel lock and setup for each page of User Defined Button.	
Misc		Current status and setup for settings not included in other pages.	Page 49
	Scene Store	Current status and setup for scene store accessibility.	
	Last Mem. Resume	Indicates and determines whether the previous memory contents will be retained when the unit is restarted.	
	Event Scheduler	Current status and setup whether an event schedule setup in the DME Designer will be executed or not.	
	Internal HA Ctrl	Determines the connector that will be used to control the internal head amp.	
	Remote	Current status and setup for the [REMOTE] connector.	
WCLK		Current status and selection of the DME64N/24N word clock.	Page 50
	Fs	Displays the word clock frequency.	
	Int	Current status of the internal word clock.	
	WCIN	Current status of the word clock received at the [WORD CLOCK IN] connector.	
	Cascade	Current status of the word clock received via the [CASCADE IN] and [CASCADE OUT] connectors.	
	SLOT1-4	Current status of the word clock received via cards plugged in to the I/O card slots.	
Slot		Displays info about an I/O card installed in a DME64N/24N I/O slot.	Page 51
	Card name	Displays the name of the installed card.	
	(no title)	Resets the installed card.	
	Format	Displays the audio format – 88.2 or 96 kHz.	
MIDI		Current status and setup for MIDI functions.	Page 51
	Port	Current status and setup of the MIDI port.	
	DAW	Current status and setup for connected MIDI devices.	
	CH	Current status and setup for the MIDI transmit and receive channels.	
	Program Change	Current status and setup for program change transmission/reception, omni on, and echo on/off.	
	Control Change	Current status and setup for control change transmission/reception, omni on, and echo on/off.	
	Param Change	Current status and setup for parameter change transmission/reception, omni on, and echo on/off.	
GPI		GPI connector calibration and status display.	Page 53
	Reset	Resets the GPI calibration.	
	Max	Sets the maximum calibration value.	
	Min	Sets the minimum calibration value.	
	(no title)	Current calibration status.	
HA		Current status and setup for the internal and connected external head amplifiers.	Page 54
	HA	Current status and setup for head amplifier type.	
	WCLK	Current status and setup for the word clock used by the head amplifier(s).	
	(no title)	Displays the audio format 88.2/96 kHz.	
	Gain	Current status and setup for individual head amplifier channel gain.	
	+48V	Current status and setup for individual head amplifier channel phantom power supply (+48V ON/OFF).	
	(no title)	Displays current status of the master phantom power switch.	
	HPF	Current status and setup for individual head amplifier channel high-pass filter on/off.	
	Frq	Current status and setup for individual head amplifier channel high-pass filter frequency.	

Page	Item	Description	Manual Page
CASCAD (DME64N only)		Displays current status for the [CASCADE] connectors.	Page 55
	Head Margin	Displays current status for the head margin of the audio signal handled via the [CASCADE] connectors.	
	Unit No.	Displays how many devices the unit is from the beginning of the cascade chain.	
	Mixer I/O	Displays current status for the channels to be used for audio signals cascaded to a mixer.	
Check	Mode	Current status and setup for the thru connection.	Page 56

Utility Display Operation

The general procedure for operating the Utility displays is outlined below.

1. Press the [UTILITY] key for longer than 2 seconds from the Main display to go to the Utility display.
2. Press the [UTILITY] key as many times as necessary until the desired parameter page appears.
3. Use the cursor keys – [◀][▲][▼][▶] – to select the parameter you want to edit.

NOTE

On the ICP1 the function buttons are used in place of the cursor keys as follows:

- [F1] key: Left
- [F2] key: Up
- [F3] key: Right
- [F5] key: Down

4. Press the [ENTER] key.

This either confirms a selection or edit, or calls the appropriate parameter edit page.

Info Page

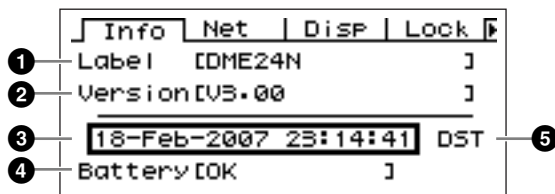

NOTE

The date and time (3) and the internal battery status (4) are not shown on the ICP1 control panel display.

- 1 Label

Shows the name. The name can be changed via the DME Designer application running on a computer connected to the unit.

NOTE

The name can not be changed from the DME64N/24N controls.

- 2 Program Version

This is the current firmware version number.

- 3 Date

Shows the currently set date and time. The internal clock and calendar can be set here.

Edit using the “Numeric Parameters” editing procedure described on page 36.

NOTE

“Zone slave” cannot be used to set this parameter.

Date/Time Parameter Edit Dialog



Day - Month - Year Hour : Minute : Second

- 4 Battery

Shows the status of the internal battery. “Low Battery” will appear when the battery needs to be replaced, and “No Battery” will appear when no battery is present in the device.

- 5 Daylight Saving Time

If you enable daylight saving time, the display will indicate “DST.”

You can enable daylight saving time using DME Designer from a connected computer.

NOTE

Daylight saving time cannot be set on the DME64N/24N itself.

Network Settings (Net) Page

Shows the Ethernet network address and other parameters.

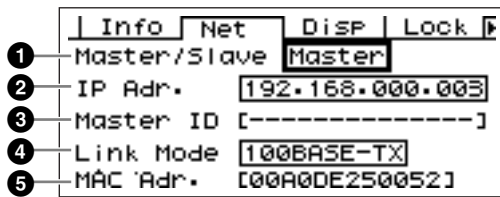

1 Master/Slave

Indicates whether or not the device is functioning as the device group master: “Master” or “Slave.”

Master: the device is the device group master.

Slave: the device is a device group slave.

Edit using the “List Parameters” editing procedure described on page 38.

NOTE

Device group status of ICP1 is fixed to “Slave.” This cannot be changed.

NOTE

Make sure that one device group master is assigned for each device group.
If no device group master is assigned, no scene information will appear on the display and scene-related control will not be possible. Mute operations will also not be possible.

2 IP Adr.

This is the device’s IP address.

Edit using the “Numeric Parameters” editing procedure described on page 36.

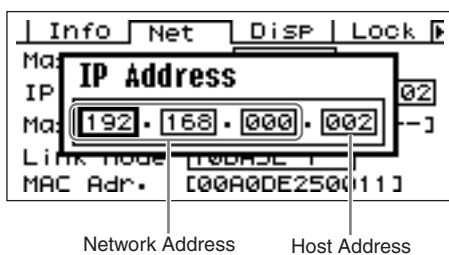

NOTE

The network addresses of devices in the same device group must be the same.

NOTE

Device group master’s IP address can be changed via the DME Designer application running on a computer connected to the unit.

3 Master ID

Displays and sets the device group master host address.

NOTE

This is not displayed on the device group master device.

4 Link Mode

Shows the status of the [NETWORK] connector. The [NETWORK] connector can be set to operate in “10Base-T” or “100Base-TX” mode.

10Base-T: The [NETWORK] connector is compatible with 10Base-T operation.

100Base-TX: The 100Base-Tx: [NETWORK] terminal operates as 100Base-TX if possible. If the network environment does not support 100Base-TX, it operates as 10Base-T.

Edit using the “List Parameters” editing procedure described on page 38.

5 MAC Adr.

This is the device’s MAC (Media Access Control) address.

NOTE

The MAC address is also known as the Ethernet address, and is an independent address assigned to all Ethernet devices. No two devices anywhere in the world can have the same address.

Display Setup (Disp) Page

Provides access to a number of display parameters.

NOTE

The meter fall time (3) is not shown on the ICP1 control panel display.

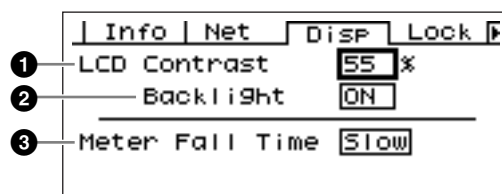

1 LCD Contrast

The current LCD contrast setting. This parameter can be adjusted from 0% through 100%.

Edit using the “Numeric Parameters” editing procedure described on page 36.

② LCD Backlight

Specifies LCD backlight operation. Two settings are available: “ON,” and “OFF.”

ON: The display is continuously lit.

OFF: The display lights when a control is operated, and will go out 10 seconds after panel operation ceases.

Pressing the [ENTER] key alternately selects “ON” and “OFF”.

③ Meter Fall Time

Determines the fall time of the level meters – “Fast” or “Slow.”

Fast: The meters rapidly follow changes in the signal level.

Slow: The meters fall slower than the actual changes in the signal level, allowing easier reading in some cases.

Edit using the “List Parameters” editing procedure described on page 38.

Security Setup (Lock) Page

Panel lock and related settings.

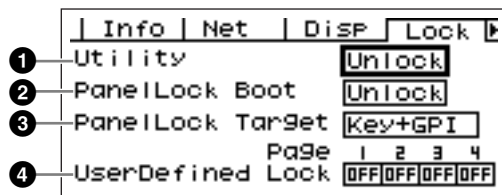

① Utility

The lock status for the Utility display settings. This parameter can be set to “Unlock” or “Lock.”

Unlock: The Utility display can be accessed without a password.

Lock: A password must be entered to access the Utility display.

When “Lock” is selected a password entry window will appear when the [UTILITY] key is pressed to access the utility pages.

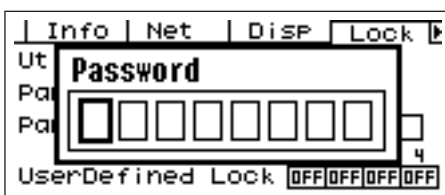

Use the [◀] and [▶] keys to position the cursor, and the dial to enter the desired character at the cursor

location. When all of the password’s characters have been entered as required press the [ENTER] key.

The password will also be required when switching from the “Unlock” mode to the “Lock” mode.

NOTE

Password security and management is very important!
If you forget your password the unit cannot be operated!
If you forget your password contact the system administrator.
If the password become unrecoverable for some reason and you need to unlock the system, please contact your Yamaha representative.

② Panel Lock Boot

Determines whether or not panel lock will be on when power to the device is turned on. This parameter can be set to “Unlock” or “Lock.”

Unlock: Panel lock is OFF when power to the device is turned on.

Lock: Panel lock is ON when power to the device is turned on.

③ Panel Lock Target

Determines the controls (control functions) to be affected by panel lock. The available settings are “Key Only” and “Key+GPI.”

Key Only: Panel lock only affects the panel keys.

Key+GPI: Panel lock applies to the panel keys as well as GPI control input.

NOTE

See page 36 for details on how to use the Panel lock feature.

NOTE

This parameter is displayed, but cannot be changed on the ICP1 display.

④ User Defined Lock

Sets the lock status individually for each of the four User Defined Button pages.

ON: The corresponding User Defined Button will not appear on the display.

OFF: The corresponding User Defined Button will appear on the display.

To change the settings use the [◀] and [▶] keys to move the cursor to the setting for the desired page, the press the [ENTER] key to alternately turn the setting “ON” and “OFF.”

NOTE

The User Defined Button are accessed as described in the “Parameter Edit Display” section on page 36.

Miscellaneous Setup (Misc) Page

This page includes parameters not available in any other page.

NOTE

The Remote setting (2) will not appear on the ICP1 control panel display.

	Misc	WCLK	Slot	MIDI
1	Scene Store			Enable
2	Last Mem. Resume			ON
3	Event Scheduler			ON
3	Internal HA Ctrl			OFF
4	Remote			HA Ctrl :422

1 Scene Store

Determines whether or not scene store operations are allowed. This parameter can be set to “Enable” or “Disable.”

Enable: Scene store operations are allowed.

Disable: Scene store operations are prohibited.

Edit using the “List Parameters” editing procedure described on page 38.

NOTE

This item cannot be set if Internal HA Ctrl is set to Remote.

NOTE

This setting applies to individual devices only. Even if one DME64N/24N unit is set to “Disable,” scene store operations will be possible via another DME64N/24N in the same device group that is set to “Enable.”

2 Last Mem. Resume

This parameter displays and determines whether the DME64N/DME24N will recall the current scene when started up, or whether the memory contents at the time the unit was turned off will be recalled. The possible settings are “ON” or “OFF”.

ON: The memory contents at the time the unit was turned off will be recalled at startup.

OFF: The current scene will be recalled at startup.

NOTE

This parameter can be changed from the device group master only.



If “Last Mem. Resume” is set to ON, the unit will back up data to the internal memory periodically. In this case, do not turn off the power to the unit within five (5) seconds after you operate any parameters.

3 Event Scheduler

Determines whether an event schedule setup in the DME Designer will be executed or not, and displays the current status. This parameter can be set to “ON” or “OFF.”

ON: The event will be executed.

OFF: The event schedule will not be executed.

Edit using the “List Parameters” editing procedure described on page 38.

NOTE

This parameter can be changed from the device group master only.

4 Internal HA Ctrl (Internal head amp control)

Determines the connector that will be used to control the internal head amp.

From a single digital mixer, you can control the internal head amps of multiple DME series units within the device group.

Set this parameter only on the DME series unit that is connected directly to the digital mixer, and turn it “OFF” for other units.

Edit using the “List Parameters” editing procedure described on page 38.

OFF: Set this “OFF” if a digital mixer is not connected directly.

Remote: The internal head amp will be controlled from the digital mixer via the [REMOTE] connector.

Slot1{Slot1–Slot4 (DME64N)}: The internal head amp will be controlled from the digital mixer via the selected slot.

NOTE

This page will not be displayed on the ICP1.

5 Remote

Determines the [REMOTE] connector communication mode.

Edit using the “List Parameters” editing procedure described on page 38.

Displays the settings of the [REMOTE] terminal.

HA Control (422)

Allows remote head amp control.

Always use this setting when a remote head amp unit (AD8HR, AD824) is connected. Also, don't change the setting while a remote head amp is connected. Doing so can damage the unit.

COM (232C)

Allows control of DME64N/DME24N units from AMX and Crestron type external controllers using DME Communication Protocol*.

COM (422)

Allows from AMX and Crestron type external controllers via the RS-232C interface using DME Communication Protocol*.

MIDI (232C)

Allows control of DME64N/DME24N units from external MIDI controllers via the RS-232C interface.

MIDI (422)

Allows control of DME64N/DME24N units from external MIDI controllers via the RS-422 interface.

Remote Ctrl (232C)

Allows control of DME64N/DME24N units from external devices via the RS-232C interface.

Remote Ctrl (422)

Allows control of DME64N/DME24N units from external devices via the RS-422 interface.

* For details on the DME Communication Protocol refer to the “DME Remote Control Protocol Specifications” document. Information about the “DME Remote Control Protocol Specifications” document can be found at the Yamaha Pro Audio website (<http://www.yamahaproaudio.com/>).

NOTE

This item cannot be set if Internal HA Ctrl is set to Remote.

Word Clock Setup (WCLK) Page

Shows the status of incoming word clock signals, and allows setup of the DME64N/24N master word clock.

NOTE

This page will not be displayed on the ICP1.

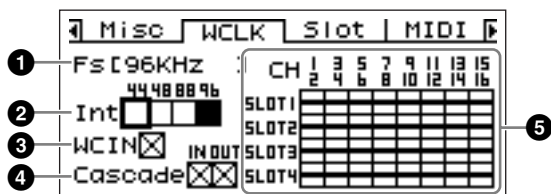

Master Clock Selection Procedure

1. Use the cursor [◀], [▲], [▼], [▶] keys to select one of the square blocks representing the available master clock sources.
2. Press the [ENTER] key to select the master clock.

1 Fs

The current sampling frequency of the master word clock. The value shown here is determined by the system's master word clock signal. To select the word clock to be used as the master, move the cursor to the appropriate word clock indication in this display – the [WORD CLOCK IN] clock, the cascade clock, or a slot clock, for example – and press the [ENTER] key.

2 Int

Sets the frequency of the internal word clock – 44.1 kHz, 48 kHz, 88.2 kHz, or 96 kHz.

3 WCIN

Shows the status of the word clock signal at the [WORD CLOCK IN] connector.

4 Cascade

Shows the status of the word clock signal at the [CASCADE IN] and [CASCADE OUT] connectors.

5 SLOT1~4

Shows the status of the word clock signal input via I/O cards installed in the I/O slots.

The Status Icons

<input type="checkbox"/>	A word clock signal is present, and this signal can be selected as the DME64N/24N word clock.
<input checked="" type="checkbox"/>	No word clock signal (cannot be selected as the master clock).
<input checked="" type="checkbox"/>	A word clock signal is present, but is not in sync with the master word clock.
<input checked="" type="checkbox"/>	Currently selected as the DME64N/24N word clock.
<input checked="" type="checkbox"/>	Currently selected as the DME64N/24N word clock, but the clock signal is not useable.
<input type="checkbox"/>	Inactive slot channel, or no I/O card is present in the slot.

Slot Information (Slot) Page

Displays the name of the card installed in an I/O card slot. Some cards can also be reset via this page.

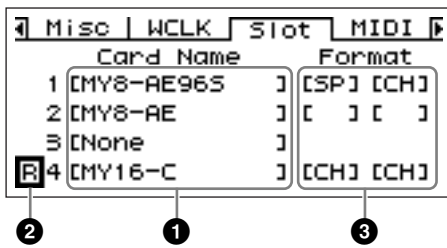

NOTE

This page will not appear on the ICP1 display.

1 Card Name

The name of the installed card appears here.

2 Reset

Resets the installed card.

3 Format

Displays the 88.2/96 kHz audio signal transfer mode. The input setting is on the left and the output setting is on the right.

No Display (Default): 44.1/48 kHz audio signal transfer.

SP (Double Speed): An 88.2/96 kHz capable card is installed, allowing direct transfer at 88.2 or 96 kHz.

CH (Double Channel): A 44.1/48 kHz card is installed, and 88.2 or 96 kHz audio is transferred by using two 44.1/48 kHz channels to transfer each channel of 88.2/96 kHz audio. The number of audio channels that can be handled in this mode is half the number of channels normally handled by the card.

MIDI Setup (MIDI) Page

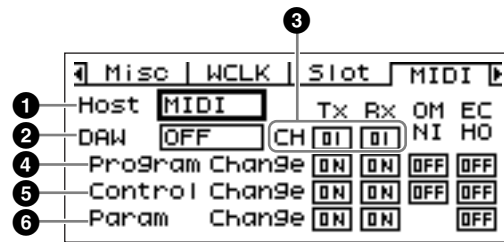

NOTE

This page will not appear on the ICP1 display.

1 Host

Determines the active MIDI port: MIDI, USB-1, USB-2, SLOT-1, SLOT-2, SLOT-3, or SLOT-4.

MIDI: The MIDI connector is the currently active MIDI port.

USB-1, USB-2: The corresponding USB port is selected for MIDI input.

SLOT-1, SLOT-2, SLOT-3, SLOT-4: A card installed in the corresponding I/O slot is currently selected for MIDI input.

Edit using the “List Parameters” editing procedure described on page 38.

NOTE

When the DME64N/24N is functioning as the device group master and is connected to a computer running the DME Designer application via USB, the MIDI port being used by the DME Designer will not be available.

2 DAW

Specifies the type of MIDI device (DAW control surface, etc.) to be connected. The choices are OFF, TYPE1, and TYPE2.

OFF: Use this setting when any MIDI device other than a general-purpose ProTools controller (HUI protocol) or general-purpose Logic or Cubase controller (Mackie control protocol) is to be connected.

TYPE1: Use this setting when a general-purpose ProTools controller (HUI protocol) is to be connected.

TYPE2: Use this setting when a general-purpose Logic or Cubase controller (Mackie control protocol) is to be connected.

Edit using the “List Parameters” editing procedure described on page 38.

Refer to the DAW controller owner’s manual as well as the DME Designer manual for setup details.

NOTE

“DAW” stands for “Digital Audio Workstation.” ProTools, Logic, and Cubase are DAW applications, and this parameter provides direct compatibility with a number of physical controls surfaces that are available for use with these DAW software packages.

The following parameters are available when the DAW parameter is set to OFF.

3 CH

Specifies the device’s MIDI transmit and receive channel: 1 ~ 16.

Edit using the “List Parameters” editing procedure described on page 38.

4 Program Change

Turns transmission and reception, the omni mode, and echo ON or OFF for MIDI program change messages. Move the cursor to the required parameter, then press the [ENTER] key to alternately turn ON and OFF.

5 Control Change

Turns transmission and reception, the omni mode, and echo ON or OFF for MIDI control change messages. Move the cursor to the required parameter, then press the [ENTER] key to alternately turn ON and OFF.

6 Parameter Change

Turns transmission and reception, and echo ON or OFF for MIDI parameter change messages. Move the cursor to the required parameter, then press the [ENTER] key to alternately turn ON and OFF.

DAW Control**1. Parameter Control Function**

Lets you control DME64N/24N parameters using a DAW Controller.

For example, if the PAN parameter is assigned to CH1 of the DAW controller, you can control the PAN parameter by operating a knob.

There are two modes in the parameter control function, as follows:

(1) General Parameter Operation Mode

[KNOB] and [CH FADER] controls are used to operate internal parameters assigning them in DME Designer.

For detailed settings, see the “DME Designer Owner’s Manual.”

(2) Final Output Stage Parameter Operation Mode

Final output stage parameters are operated using [MUTE] and [CH FADER] controls.

Unlike the General Parameter Control Mode, controls and the parameters that are compatible with them, are fixed in this mode.

[Method of Operation]

[▲]: Switches to General Internal Parameter Control Mode.

[▼]: Switches to Final Output Stage Parameter Control Mode.

[BANK <][BANK >]: The channels targeted for operation are shifted by the number of channels built into the DAW controller.

[CH <][CH >]: The channels targeted for operation are shifted one channel at a time.

[SELECT]: Switches the display method on the DAW controller.

When turned OFF, an overall display appears. When a channel is turned ON, the detail display appears for that channel.

For information about the overall and detail displays, see the next item, “Setting and Parameter Name Display Function.”

[KNOB]: Changes assigned parameters in the General Internal Parameter Operation Mode.

This is not used in the Final Output Stage Parameter Operation Mode.

[MUTE]: This is not used in the General Internal Parameter Operation Mode.

This turns muting ON or OFF for the corresponding channel in the Final Output Stage Parameter Operation Mode.

[CH FADER]: Changes assigned parameters in the General Internal Parameter Operation Mode.

This adjusts volume for the corresponding channel in the Final Output Stage Parameter Operation Mode.

NOTE

Only one parameter can be assigned to the same channel.

2. Setting and parameter name display function

Displays the settings and parameter names on the DAW controller's LCD screen.

There are two display methods: over-all display and detail display.

Overall Display:

The overall display shows the assigned parameter names and settings, organized by DAW channels.

Detail Display:

In the detail display, you select the parameter you want to display. Only information for that parameter appears on the DAW controller's LCD screen.

NOTE

The number of characters that can be displayed is limited by the size of the DAW's LCD screen.

3. User Label Function

Lets you attach names to assigned parameters.

For details about settings, see the "DME Designer Owner's Manual."

GPI Setup (GPI) Page

Input calibration parameters for the [GPI] connector.

NOTE

This page will not appear on the ICP1 display.

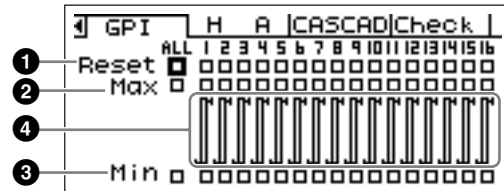

1 Reset

Resets GPI calibration.

To reset the calibration, use the [◀] [▲] [▼] [▶] keys to select ALL to reset all inputs, or select an individual input from 1 to 16 to be reset, then press the [ENTER] key.

2 MAX

Sets the maximum calibration value.

To set the MAX value, use the [◀] [▲] [▼] [▶] keys to select ALL to set all inputs, or select an individual input from 1 to 16 to be set, then press the [ENTER] key to set the MAX value to the current input voltage.

3 MIN

Sets the minimum calibration value.

To set the MIN value, use the [◀] [▲] [▼] [▶] keys to select ALL to set all inputs, or select an individual input from 1 to 16 to be set, then press the [ENTER] key to set the MIN value to the current input voltage.

4 Calibration Info

Shows the calibration settings as well as the current input voltage.

Head Amplifier Setup (HA) Page

Provides access to the head amplifier settings. Refer to “REMOTE Connection” on page 28 for head amplifier control signal connection.

NOTE

This page will not appear on the ICP1 display.

NOTE

Some scenes include head amplifier settings. In such cases, the HA page settings will be saved along with the scene when it is stored.

Internal Head Amplifier (DME24N only)

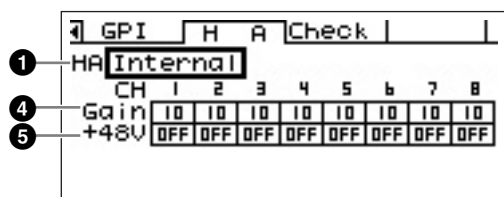

AD8HR

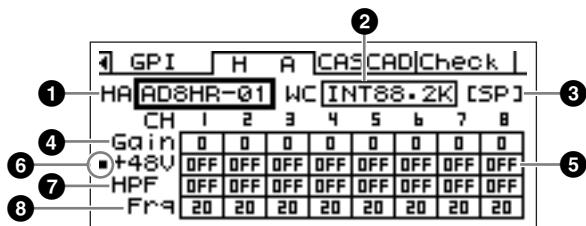

AD824

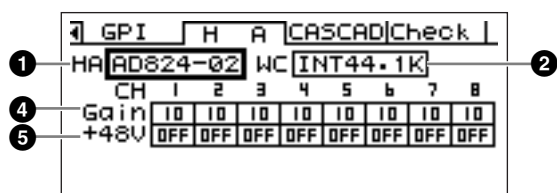

1 HA

Specifies the type of head amplifier to be set up. The available options are AD8HR, AD824, and Built-in HA (DME24N only). When the AD8HR and AD824 are selected, a number indicating the connection order will also appear.

Edit using the “List Parameters” editing procedure described on page 38.

2 WCLK (AD8HR/AD824 only)

Specifies the word clock signal to be used by the head amplifier(s).

Available settings of the AD8HR are “D OUT A,” “WCLK IN,” “INT44.1K,” “INT48K,” “INT88.2K,” and “INT96K.”

D OUT A: Sets the word clock signal at the digital input as the master clock of the AD8HR.

WCLK IN: Sets the word clock signal at BNC connector as the master clock of the AD8HR.

INT44.1K: Sets the 44.1 kHz internal word clock as the master clock of the AD8HR.

INT48K: Sets the 48 kHz internal word clock as the master clock of the AD8HR.

INT88.2K: Sets the 88.2 kHz internal word clock as the master clock of the AD8HR.

INT96K: Sets the 96 kHz internal word clock as the master clock of the AD8HR.

Available settings of the AD824 are “SLOT,” “BNC,” “INT44.1K,” and “INT48K.”

SLOT A: Sets the word clock signal input via I/O cards installed in the I/O slots as the master clock of the AD824.

BNC: Sets the word clock signal at the BNC connector as the master clock of the AD824.

INT44.1K: Sets the 44.1 kHz internal word clock as the master clock of the AD824.

INT48K: Sets the 48 kHz internal word clock as the master clock of the AD824.

3 Format (AD8HR only)

Displays the 88.2/96 kHz audio signal transfer mode. The input setting is on the left and the output setting is on the right.

No Display (default): 44.1/48 kHz audio signal transfer.

SP (Double Speed): Allows direct transfer at 88.2 or 96 kHz.

CH (Double Channel): 88.2 or 96 kHz audio is transferred by using two 44.1/48 kHz channels to transfer each audio channel of 88.2 and 96 kHz respectively. The number of audio channels that can be handled in this mode is half the number of channels normally handled by the AD8HR.

4 Gain

Individually sets the gain of each head amplifier channel. Edit using the “Numeric Parameters” editing procedure described on page 36.

NOTE

The gain of the DME24N internal head amplifiers can be adjusted from +10 dB to -60 dB in 1-dB increments. The internal circuitry switches at about the -45-dB point, and the signal is automatically muted at that point to prevent noise. The AD8HR gain can be adjusted from +10 dB to -62 dB in 1-dB steps, and the AD824 gain can be adjusted from +10 dB to -62 dB in 6-dB steps.

The PAD will be internally switched on or off when the gain of the DME24N built-in head amplifier is adjusted between -8 dB and -7 dB. Keep in mind that noise may be generated if there is a difference between the Hot and Cold output impedance of the external device connected to the IN connector when using phantom power.

5 +48V

Individually turns phantom power ON or OFF for each head amplifier channel.

Use the [◀] and [▶] keys to position the cursor at the desired channel, then press the [ENTER] key to alternately turn phantom power for that channel ON and OFF.



- Always turn the phantom power off when it is not needed.
- When turning phantom power ON, make sure that no equipment other than phantom-powered devices such as condenser microphones are connected to the [IN] connectors (DME24N only). Applying phantom power to a device that does not require phantom power can damage the device.
- Do not connect or disconnect a device to a [IN] connector (DME24N only) while phantom power is applied. Doing so can damage the connected device and/or the unit itself.
- To prevent speaker and possible hearing damage, be sure to turn power amplifiers OFF when turning phantom power ON or OFF. It is also a good idea to turn the output level all the way down (page 39).

6 Phantom Master Switch (AD8HR only)

Displays overall phantom power ON or OFF.

7 High-pass Filter (HPF) (AD8HR only)

Individually turns the high-pass filter for each AD8HR head amplifier channel ON or OFF. This parameter is only available for the AD8HR head amplifier. Use the [◀] and [▶] keys to select a channel, then press the [ENTER] key to turn the HPF for that channel ON or OFF.

8 High-pass Filter Frequency (Frq) (AD8HR only)

Individually sets the high-pass filter frequency for each AD8HR head amplifier channel. This parameter is only available for the AD8HR head amplifier. Edit using the “Numeric Parameters” editing procedure described on page 36.

Cascade Setup (CASCAD) Page

Shows the status of the [CASCADE] connectors. Refer to “CASCADE Connection” on page 31 for connection details.

Settings are made from the DME Designer application running on the connected computer.

NOTE

This page only appears on the DME64N.



1 Head Margin

Sets the head margin for cascade connection.

-18dB: Use this setting when cascading DME64N units or when connecting to a mixer’s normal cascade bus.

0dB: Use this setting when connecting to a PM5D in situations in which the PM5D SLOT OUT port signal is being output via the CASCADE OUT terminal.

NOTE

The Head Margin setting only applies when connected to a mixer. When not connected to a mixer the head margin is automatically set to 0 dB.

2 Unit No

Shows how many devices the unit is from the beginning of the cascade chain.

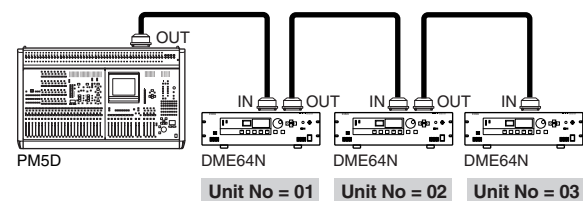

3 Mixer I/O

Displays whether the cascade signal is bus shared or not.

■: A DME64N connected directly to the mixer is connected to a second DME64N on this unidirectional channel.

Input on the same channel from other DME64N units will be independent.

□: This channel is being used for bidirectional bus shared connection between DME64N units. Input on the same channel from other DME64N units will be summed.

NOTE

Make sure that the Mixer I/O setting is the same for all cascaded DME64N/24N units.

Check Page

Even in an environment with no computer, you can check the connections without using DME Designer by directly connecting the DME64N/24N input/output.

The meter does not operate during a connection check.

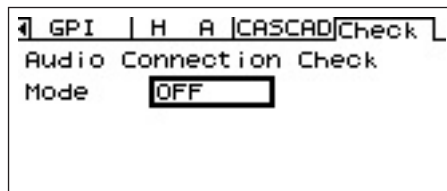

MODE: OFF

Makes connections in the configuration used in the current scene.

This is set to OFF when the unit is started.

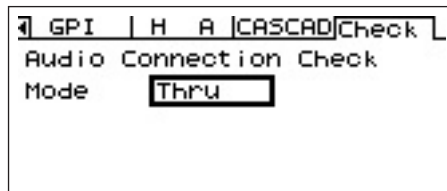

MODE: Thru

Directly connects the Input and Output of each slot one-to-one for each channel.

When input-only or output-only cards like AD or DA cards are inserted in the slots, you cannot perform checks in this mode.

In the DME24N, the internal AD and internal DA are directly connected on each channel.

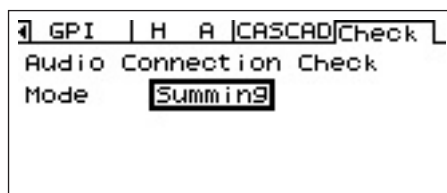

MODE: Summing

Sums all input signals coming from Inputs (-12dB), without regard to device or card type, and outputs it through all Outputs.

NOTE

This page will not appear on the ICPI display.

References

Options

The ICP1, CP4SW, CP1SF, and CP4SF controllers are available as options for remote external control of the DME series. The ICP1 connects via Ethernet, while the CP4SW, CP1SF, and CP4SF connect via the GPI interface. For more information on installing your Control Panel and connecting it to a DME series unit, refer to the owner's manual that came with the Control Panel. For more information on settings, refer to the DME Designer Owner's Manual.

ICP1

This controller connects to a DME series unit via Ethernet. Like the DME series units, a unique IP address must be assigned to each controller unit. Data is transmitted and received via Ethernet cables.

You can assign and control any function of all DME series units in the same device group via the controller.

Up to four parameter sets can be assigned to six function keys (F1 – F6) located above and under the LCD. You can control up to 24 parameters by selecting a display page using the [HOME] key.

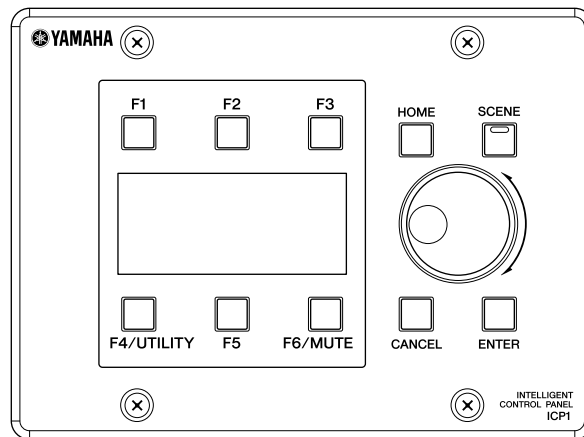

CP4SW, CP4SF, and CP1SF

These controllers connect to DME series units via the [GPI] connectors. These controllers control only the DME series units to which they are directly connected. The controller switches enable you to turn the parameter settings On and Off. The switch LEDs enable you to check the parameter status. The faders enable you to control the parameter values.

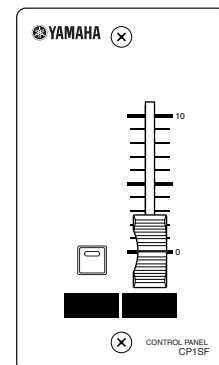
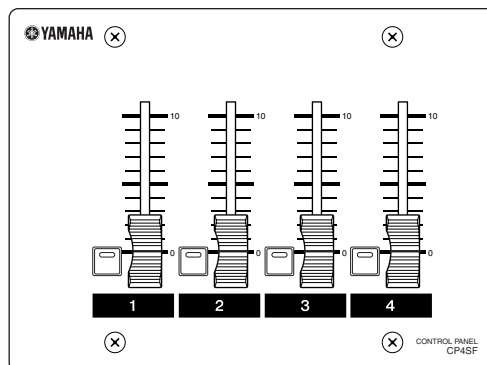
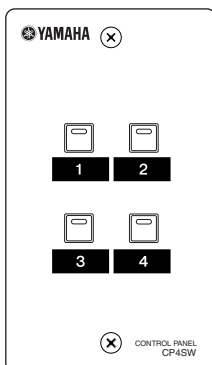

Error Messages

Message	Meaning	Action
Error messages		
Cannot Select	No selectable items are available in the scene or monitoring point list display.	Make the appropriate settings via the DME Designer application.
Component Corrupt Update Firmware!	The component data is corrupt or can't be found.	Restart after updating the component using DME Designer. If the error indicators are still indicating the error, execute the "Delete All Data" initialization. If the problem persists, contact a Yamaha dealer.
Critical Battery	The internal battery is almost discharged. Your data may be lost.	If you turn off power to the unit, the current settings may be lost and reset to the default values. Stop operating the unit, and contact a Yamaha dealer for battery replacement.
Int.Data Corrupt	Data inside the internal flash memory has been erased.	Execute the "Delete All Data" initialization. If the problem persists, contact a Yamaha dealer.
Invalid Password	An invalid password has been entered.	Enter the correct password. If you have lost or forgotten your password, contact a Yamaha dealer.
Log Buffer Full	Saving is not possible, since the Event Log saving area is full.	Use DME Designer to delete the log.
Low Battery	The backup battery voltage is low.	This does not affect the operation of the unit. However, if you continue using the unit, the settings may be lost and reset to the default values. Contact a Yamaha dealer for battery replacement at your earliest convenience.
No Battery	The internal battery is completely discharged or not installed.	If you turn off the power to the unit, the current settings will be lost and reset to the default values. Stop operating the unit, and contact a Yamaha dealer for battery replacement.
Param Access Err	The current setting cannot be displayed because the parameter you attempted to operate does not exist. It is possible that the component is not operating normally.	Save the current settings using DME Designer, execute the initialization (Delete All Data). If the problem persists, contact a Yamaha dealer.
Param Set Err	The current setting cannot be changed because the parameter you attempted to operate does not exist. It is possible that the component is not operating normally.	Save the current settings using DME Designer, execute the initialization (Delete All Data). If the problem persists, contact a Yamaha dealer.
ResumeData Corrupt Recall a Scene!	The data has been partially corrupted due to power shutdown while writing to the internal memory. The current settings have been lost.	Recall the scene again. If the problem persists, contact a Yamaha dealer.
Resume Data Lost! Recall a Scene!	Current setting has been lost.	Recall the scene again. If the problem persists, contact a Yamaha dealer.
Saving Failed	A save operation has failed.	Stop using the device immediately and contact a Yamaha dealer.
Slots Overloaded	The current being used by all cards installed in I/O slots exceeds the rated limit.	Make sure that the total current consumption of the cards used does not exceed the limit.
Store Disable	The scene store parameter is set to "Disable."	Set the scene store parameter to "Enable" via the Utility display "Lock" page.
Storing Failed	Either the flash memory for storing data is full, or the file system has been damaged.	Reduce the number of unused scenes. Alternatively, delete the files saved via the File Storage function. If deleting these items does not solve the problem, execute the Delete All Data initialization. If the problem persists, contact a Yamaha dealer.
Used by ExDevice	The connector selected by the Internal HA Ctrl parameter or the MIDI Port parameter is already being controlled by an external device (such as the PM5D).	Stop control from the external device. If it is being controlled from the PM5D, turn off the CONNECT button in the PM5D's DME CONTROL screen.
Used by HA Ctrl	The connector selected by the MIDI Port parameter is already selected for internal head amp control from an external device.	Set the Internal HA Ctrl parameter to something other than the connector you want to select for the MIDI Port parameter.
Used by MIDI	This cannot be set, since the connector selected by the Internal HA Ctrl parameter is already used by the MIDI function.	Set the MIDI Port parameter to something other than the connector you selected for Internal HA Ctrl.
Status messages		
Cable Disconnect	No network cable connected.	Make sure that a network cable is properly connected, and that all network devices are functioning normally.
Cannot be assigned	No parameter assigned.	—
Cannot Store	The scene data is protected.	Set the protect parameter to "OFF" via the DME Designer application.
CAS. In Sync Err	The DME64N/24N clock is not in sync with the clock signal being received at the [CASCADE IN] connector.	Make sure that the DME64N/24N and the card or external source supplying the word clock are set to use the same word clock.
CAS. Out Sync Err	The DME64N/24N clock is not in sync with the clock signal being received at the [CASCADE OUT] connector.	Make sure that the DME64N/24N and the card or external source supplying the word clock are set to use the same word clock.

Message	Meaning	Action
Connection to Master DME is Lost	Communication with the master DME device has been interrupted.	Check that all cables are properly connected, and that hubs, routers, and related devices are functioning properly.
Connection to Slave SME is Lost	Communication with the slave DME device has been interrupted.	Check that all cables are properly connected, and that hubs, routers, and related devices are functioning properly.
Download Success	The program has been successfully updated.	—
Downloading Do not turn off	Program update in progress. Do NOT turn power off while the unit displays this message.	—
DSP Power Shortage	Audio is not input or output and is muted due to insufficient DSP resources.	This error sometimes occurs if you try to operate a configuration at 96 kHz that has been created with a word clock of 48 kHz. To operate a configuration at any word clock setting, use DME Designer to create a configuration with the word clock set to 96 kHz.
Duplicate IP Adr.	Duplicate IP addresses.	Change the IP addresses so that there are no duplicates.
Err: Wrong Device Group Settings	The device group configuration set via DME Designer does not match the actual configuration.	Use DME Designer to go off-line, create a configuration that correctly matches the actual configuration, and then go back on-line to synchronize the configuration.
Executing	Direct setup from the User Defined Buttons in progress.	—
File Opening Do not turn off	A file operation is in progress during which the computer manipulates scene data. Do NOT turn power off while the unit displays this message.	—
Illegal MAC Adr.	An illegal MAC address has been encountered.	This could be due to a hardware malfunction. Refer this problem to a contact a Yamaha dealer.
Invalid IP Adr.	The network IP address is not appropriate.	Set an appropriate network IP address.
Network Busy	There is too much network traffic. Communication is not possible.	Check the devices connected to the network. If there are too many devices connected, reduce the number of devices.
Network Error	One of the following errors has occurred on the network: <ul style="list-style-type: none"> • A cable has been unplugged. • The power to a hub or router has been shut off. • A cable is in an inappropriate state (e.g. a heavy object has been placed on the cable, etc.). Static electricity can also cause errors. 	Locate and eliminate the cause of the error.
Network Setup	Preparing network connection.	—
No Current Scene	There is no data in the current scene.	Send appropriate scene data from a computer running the DME Designer application.
No MAC Adr.	MAC address not specified.	This could be due to a hardware malfunction. Refer this problem to a Yamaha dealer.
Panel Locked	Panel operation not allowed.	Press the [CANCEL] button for longer than 2 seconds to disengage panel lock and allow panel operation.
Panel Unlocked	Panel lock has been disengaged. Panel operation is now possible.	—
Recovering Do not turn off	A program update attempt has failed, and the previous program is currently being restored.	Do NOT turn power off while the unit is displaying this message. If the update attempt repeatedly fails, there may be a hardware malfunction. Refer this problem to a Yamaha dealer.
Saving HA Info Do not turn off	Head amplifier info save in progress. (Do not turn power off.)	—
Saving Setup Info Do not turn off	Info set up via the Utility display (other than head amplifier info) is being saved. (Do not turn power off.)	—
Scene Recalling Do not turn off	Scene recall in progress. Do NOT turn power off while the unit displays this message.	—
Scene Storing Do not turn off	Scene store in progress. Do NOT turn power off while the unit displays this message.	—
Searching for Master DME Unit...	Currently searching for the master DME unit.	—
Searching for Slave DME Unit...	Currently searching for the slave DME unit.	—
SLOT1 Sync Err	The DME64N/24N clock is not synchronized with the clock of the card installed in I/O slot 1.	Make sure that the DME64N/24N and the card or external source supplying the word clock are set to use the same word clock.
SLOT2 Sync Err	The DME64N clock is not synchronized with the clock of the card installed in I/O slot 2.	Make sure that the DME64N and the card or external source supplying the word clock are set to use the same word clock.
SLOT3 Sync Err	The DME64N clock is not synchronized with the clock of the card installed in I/O slot 3.	Make sure that the DME64N and the card or external source supplying the word clock are set to use the same word clock.

Message	Meaning	Action
SLOT4 Sync Err	The DME64N clock is not synchronized with the clock of the card installed in I/O slot 4.	Make sure that the DME64N and the card or external source supplying the word clock are set to use the same word clock.
Synchronizing Do not turn off	Data is being received from the computer. Do NOT turn power off while the unit displays this message.	—
Updating Do not turn off	Data is being received from the computer. Do NOT turn power off while the unit displays this message.	—
WCLK Unlocked	A usable word clock signal is not being received or cannot be detected.	Recheck all word clock connections and internal parameters.
WCLK In Sync Err	The DME64N/24N clock is not in sync with the clock signal being received at the WORD CLOCK IN] connector.	Make sure that the DME64N/24N and the card or external source supplying the word clock are set to use the same word clock.

Troubleshooting

The power won't turn on, and the panel indicators and LCD won't light.	<ul style="list-style-type: none"> • Is the power cable properly connected? • Is the POWER switch turned on? • If neither of the above is the problem, contact your Yamaha service center or representative.
Cannot exchange data between the DME64N/24N and the DME Designer.	<ul style="list-style-type: none"> • Are the network cables connected correctly? • Has the USB-MIDI driver been properly installed? • If you are using the [NETWORK] connector, has the DME-N Network Driver been properly set up? • Has a MIDI port been properly assigned (page 51)? • Are you using a version of DME Designer later than 3.0?
No sound input.	<ul style="list-style-type: none"> • Are the cables connected properly? • Is an appropriate signal being received from the external device? • Is the GAIN of the internal (DME24N) or external head amp set to an appropriate level?
No sound output.	<ul style="list-style-type: none"> • Are the cables connected properly? • Make sure that the output level isn't turned down (page 39). • Is MUTE ON (page 39)? • Have you used DME Designer to select a scene that does not output audio? • Are you attempting to run a configuration that is not compatible with 96 kHz operation at 96 kHz?
MIDI messages aren't transmitted or received.	<ul style="list-style-type: none"> • Is power to the MIDI device(s) turned on? • Are the MIDI ports properly set up (page 51)? • Are the receive and transmit device channels set appropriately?
Scenes are not recalled when MIDI program change messages are received.	<ul style="list-style-type: none"> • Have the settings required to receive program change messages been properly made (page 51)? • Use the DME Designer to set up the MIDI Program Change table as required.
Parameter control does not function even when MIDI control change messages are received.	<ul style="list-style-type: none"> • Make the settings required to allow control change reception. • Use the DME Designer to set up the MIDI Control Change table as required.
Parameter control does not function even when MIDI parameter change messages are received.	<ul style="list-style-type: none"> • Have the settings required to receive parameter change messages been properly made (page 51)? • Use the DME Designer to set up the MIDI Parameter Change table as required.
Slow data transfer.	<ul style="list-style-type: none"> • Set the LINK MODE to 100Base-TX (page 47).
The desired scene can't be recalled.	<ul style="list-style-type: none"> • Write the require scene data from the DME Designer to the DME64N/24N.
Scenes are recalled unexpectedly.	<ul style="list-style-type: none"> • Is input being received from an external device or the DME Designer? • Use the DME Designer to check the MIDI Program Change Table settings. • Use the DME Designer to check the GPI input assignments. • Use the DME Designer to check the Remote Control Setup List assignments.
Scenes can be recalled but not stored.	<ul style="list-style-type: none"> • Set scene store to "Enable" (page 49).
The 96kHz/88.2kHz/48kHz/44.1kHz indicator flashes red.	<ul style="list-style-type: none"> • Select a different word clock source (page 50). • If an external device is functioning as the word clock master, check that the cables are connected properly.
Noise appears on the analog outputs when an external device is the word clock master and the word clock source is switched.	<ul style="list-style-type: none"> • Reduce the power amp level to prevent speaker damage, or turn the DME64N/24N off before switching clock sources.
Use Defined Button settings change unexpectedly.	<ul style="list-style-type: none"> • Use the panel lock function (page 38) to prevent unwanted operation of the panel controls on specific DME64N/24N or ICP1 units.
User Defined Button settings cannot be changed.	<ul style="list-style-type: none"> • Use the DME Designer to make sure that multiple User Defined Buttons are not assigned to the same parameter. • Turn the User Defined Lock function off (page 38).
The panel controls cannot be operated.	<ul style="list-style-type: none"> • Is the panel lock function on (page 36)?
The Utility screen cannot be opened.	<ul style="list-style-type: none"> • Is the Utility screen lock function on (page 48)? If you have forgotten your password contact your Yamaha service center or representative.

Specifications

Specifications and descriptions in this owner's manual are for information purposes only. Yamaha Corp. reserves the right to change or modify products or specifications at any time without prior notice. Since specifications, equipment or options may not be the same in every locale, please check with your Yamaha dealer.

Sampling Frequency	Internal	44.1kHz, 48kHz, 88.2kHz, 96kHz
	External	Normal Rate: 39.69 – 50.88kHz Double Rate: 79.39 – 101.76kHz
Signal Delay (Fs = 96kHz)		DME64N: 0.85 msec (Input of MY8-AD96 to Output of MY8-DA96) DME24N: 0.5 msec ([IN] port to [OUT] port)
Memory	Configuration	16 (depends on size of data)
	Scene	999 (depends on size of data)
Display		160 x 64 dot matrix LCD with backlight
Scene No.		7-segment LED x 3
Indicators	Wordclock	EXT.CLOCK, 96kHz, 88.2kHz, 48kHz, 44.1kHz
	External Control	NETWORK, MIDI
	Zone Configuration	MASTER
	Analog Input* ¹	SIGNAL x 8, PEAK x 8
	Analog Output* ¹	SIGNAL x 8, PEAK x 8
Power Requirements		120V AC, 60Hz (USA, Canada) 230V AC, 50Hz (Europe) 100V AC, 50/60Hz (Japan)
Power Consumption		DME64N: 80W DME24N: 75W
Dimensions (W x H x D)		DME64N: 480 x 145 x 411.5mm, 3U DME24N: 480 x 101 x 411.5mm, 2U
Weight		DME64N: 9.5kg DME24N: 8kg
Temperature Range	Free-Air operating	10 – 35 °C
	Storage	-20 – 60 °C
AC Power Cord Length		2.5m
Supplied Accessories		AC power cord, Owner's Manual, AC plug clamp, 16-pin Euroblock plug x 2, 8-pin Euroblock plug x 4 (DME64N), 3-pin Euroblock plug x 16 (DME24N)

*1. Available on DME24N only

European models

Purchaser/User Information specified in EN55103-1 and EN55103-2.

Inrush Current: 39A

Conforms to Environments: E1, E2, E3 and E4

Input/Output Characteristics

DME24N ANALOG INPUT CHARACTERISTICS

Terminals	Gain	Actual Load Impedance	For Use With Nominal	Input Level		Connector
				Nominal	Max. before clip	
CH INPUT 1-8	-60dB	3kΩ	50 – 600Ω Mics & 600Ω Lines	-60dBu (0.775mV)	-40dBu (7.75mV)	Euroblock
	+10dB			+10dBu (2.451V)	+30dBu (24.511V)	

- 0dBu = 0.775 Vrms
- All AD converters (CH1-8) are 24-bit linear, 128 times oversampling.
- +48V DC (phantom power) is supplied to CH INPUT (1-8) connectors via each individual controlled switch.

DME64N ANALOG OUTPUT CHARACTERISTICS

Output Terminals	Actual Source Impedance	For Use With Nominal	Output Level		Connector
			Nominal	Max. before clip	
PHONES	15Ω	8Ω	75mW	150mW	Stereo Phone Jack
		40Ω	65mW	150mW	

- 0dBu = 0.775 Vrms
- Stereo Phone Jack = unbalanced (Tip = LEFT, Ring = RIGHT, Sleeve = GND)

DME24N ANALOG OUTPUT CHARACTERISTICS

Output Terminals	Actual Source Impedance	For Use With Nominal	Output Level		Connector
			Nominal	Max. before clip	
OUTPUT 1-8	150Ω	600Ω Lines	+4dBu (1.23V)	+24dBu (12.28)	Euroblock
PHONES	15Ω	8Ω	75mW	150mW	Stereo Phone Jack
		40Ω	65mW	150mW	

- 0dBu = 0.775 Vrms
- All AD converters (CH1-8) are 24-bit linear, 128 times oversampling.
- Stereo Phone Jack = unbalanced (Tip = LEFT, Ring = RIGHT, Sleeve = GND)

DME24N ANALOG CHARACTERISTICS (Output impedance of signal generator: 150Ω)

Frequency Response 20Hz – 20kHz, reference to the nominal output level @ 1kHz

Input	Output	RL	Conditions	Min.	Typ.	Max.	Units
CH INPUT 1-8	CH OUTPUT 1-8	600Ω	GAIN = -60dB	-1.5	0.0	0.5	dB
Internal OSC	PHONES	8Ω		-3.0	0.0	0.5	dB

Frequency Response fs = 96kHz@20Hz – 40kHz, reference to the nominal output level @ 1kHz

Input	Output	RL	Conditions	Min.	Typ.	Max.	Units
CH INPUT 1-8	CH OUTPUT 1-8	600Ω	GAIN = -60dB	-1.5	0.0	0.5	dB
Internal OSC	PHONES	8Ω		-3.0	0.0	0.5	dB

Gain Error @ 1kHz

Input	Output	RL	Conditions	Min.	Typ.	Max.	Units
CH INPUT 1-8	CH OUTPUT 1-8	600Ω	GAIN = -60dB	2.0	4.0	6.0	dBu
			GAIN = +10dB	2.0	4.0	6.0	dBu
Internal OSC	PHONES	8Ω	-30dBFS @1kHz, phones level control: max.	-2.0	0.0	2.0	dBu

Total Harmonic Distortion fs = 48kHz

Input	Output	RL	Conditions	Min.	Typ.	Max.	Units
CH INPUT 1-8	CH OUTPUT 1-8	600Ω	GAIN = -60dB @20Hz – 20kHz @+14dBu			0.1	%
			GAIN = +10dB @20Hz – 20kHz @+14dBu			0.05	%
Internal OSC	PHONES	8Ω	-30dBFS @1kHz, phones level control: max.			0.1	%

Total Harmonic Distortion fs=96kHz

Input	Output	RL	Conditions	Min.	Typ.	Max.	Units
CH INPUT 1-8	CH OUTPUT 1-8	600Ω	GAIN = -60dB @20Hz – 20kHz @+14dBu			0.1	%
			GAIN = +10dB @20Hz – 20kHz @+14dBu			0.05	%
Internal OSC	PHONES	8Ω	-30dBFS @1kHz, phones level control: max.			0.1	%

Hum & Noise EIN = Equivalent Input Noise

Input	Output	RL	Conditions	Min.	Typ.	Max.	Units
CH INPUT 1-8	CH OUTPUT 1-8	600Ω	GAIN = -60dB Master fader at nominal level and one Ch fader at nominal level. (Mixer mode)		-128		dBu
					-64		dBu
Internal OSC	PHONES	8Ω	GAIN = +10dB Master fader at nominal level and one Ch fader at nominal level. (Mixer mode)		-82		dBu
					-86		dBu

- Hum & Noise are measured with a 6dB/octave filter @12.7kHz; equivalent to a 20kHz filter with infinite dB/octave attenuation.

Dynamic Range

Input	Output	RL	Conditions	Min.	Typ.	Max.	Units
CH INPUT 1-8	CH OUTPUT 1-8	600Ω	GAIN = +10dB		106		dB

- Dynamic range are measured with a 6dB/octave filter @12.7kHz; equivalent to a 20kHz filter with infinite dB/octave attenuation.

Crosstalk @ 1kHz

From/To	To/From	Conditions	Min.	Typ.	Max.	Units
CH N	CH (N-1) or (N+ 1)	CH1 – 8, adjacent inputs			-80	dB

Maximum Voltage Gain @ 1kHz

Input	Output	RL	Conditions	Min.	Typ.	Max.	Units
CH INPUT 1-8	CH OUTPUT 1-8	600Ω	GAIN = -60dB		64		dB

Phantom Voltage

Output	Conditions	Min.	Typ.	Max.	Units
CH INPUT 1-8	hot, cold: No load	46	48	50	V

PEAK/SIGNAL Indicator Level

Input	Output	Conditions	Min.	Typ.	Max.	Units
CH INPUT 1-8	CH OUTPUT 1-8	GAIN = +10dB PEAK red LED: ON	19	21	23	dBu
		GAIN = +10dB SIGNAL green LED: ON	-18	-16	-14	dBu

Control I/O

Terminals	Format	Level	Connector
REMOTE	-	RS232C	D-SUB Connector 9-pin (Male) Baud Rate = 38,400 bps Data = 8bit Stop bit = 1bit PARITY = NON
	-	RS422	
MIDI	IN/OUT/THRU	-	DIN Connector 5P
WORDCLOCK	IN/OUT	TTL/75Ω	BNC Connector
Ethernet	Ethernet	-	RJ-45
USB	USB	0 – 3.3V	USB Type B (Female)
GPI	IN	0 – 5V	Euroblock Connector
	OUT	TTL	
	+V	5V	

DME64N: 16-GPI inputs and 16-GPI outputs

DME24N: 8-GPI inputs and 8-GPI outputs

Outputs: I_{max}/pin = 16mA

Outputs: V_H = 2.5V(min.), V_L = 0.6V(max.)

Connector Pin Assign

[CASCADE IN/OUT] Connectors (DME64N only)

CASCADE IN

Pin No.	Signal	Pin No.	Signal
1	GND	35	GND
2	INPUT 1-2 (+)	36	INPUT 1-2 (-)
3	INPUT 3-4 (+)	37	INPUT 3-4 (-)
4	INPUT 5-6 (+)	38	INPUT 5-6 (-)
5	INPUT 7-8 (+)	39	INPUT 7-8 (-)
6	INPUT 9-10 (+)	40	INPUT 9-10 (-)
7	INPUT 11-12 (+)	41	INPUT 11-12 (-)
8	INPUT 13-14 (+)	42	INPUT 13-14 (-)
9	INPUT 15-16 (+)	43	INPUT 15-16 (-)
10	DTR IN (+)	44	DTR IN (-)
11	RTS OUT (+)	45	RTS OUT (-)
12	GND	46	GND
13	WORD CLOCK IN (+)	47	WORD CLOCK IN (-)
14	WORD CLOCK OUT (+)	48	WORD CLOCK OUT (-)
15	CONTROL IN (+)	49	CONTROL IN (-)
16	CONTROL OUT (+)	50	CONTROL OUT (-)
17	GND	51	ID6 IN
18	GND	52	ID6 OUT
19	INPUT 17-18 (+)	53	INPUT 17-18 (-)
20	INPUT 19-20 (+)	54	INPUT 19-20 (-)
21	INPUT 21-22 (+)	55	INPUT 21-22 (-)
22	INPUT 23-24 (+)	56	INPUT 23-24 (-)
23	INPUT 25-26 (+)	57	INPUT 25-26 (-)
24	INPUT 27-28 (+)	58	INPUT 27-28 (-)
25	INPUT 29-30 (+)	59	INPUT 29-30 (-)
26	INPUT 31-32 (+)	60	INPUT 31-32 (-)
27	ID0 IN	61	ID1 IN
28	ID2 IN	62	ID3 IN
29	ID4 IN	63	ID5 IN
30	ID0 OUT	64	ID1 OUT
31	ID2 OUT	65	ID3 OUT
32	ID4 OUT	66	ID5 OUT
33	MSB //LSB IN	67	2CH//4CH IN
34	FG	68	FG

CASCADE OUT

Pin No.	Signal	Pin No.	Signal
1	GND	35	GND
2	OUTPUT 1-2 (+)	36	OUTPUT 1-2 (-)
3	OUTPUT 3-4 (+)	37	OUTPUT 3-4 (-)
4	OUTPUT 5-6 (+)	38	OUTPUT 5-6 (-)
5	OUTPUT 7-8 (+)	39	OUTPUT 7-8 (-)
6	OUTPUT 9-10 (+)	40	OUTPUT 9-10 (-)
7	OUTPUT 11-12 (+)	41	OUTPUT 11-12 (-)
8	OUTPUT 13-14 (+)	42	OUTPUT 13-14 (-)
9	OUTPUT 15-16 (+)	43	OUTPUT 15-16 (-)
10	DTR OUT (+)	44	DTR OUT (-)
11	RTS IN (+)	45	RTS IN (-)
12	GND	46	GND
13	WORD CLOCK OUT (+)	47	WORD CLOCK OUT (-)
14	WORD CLOCK IN (+)	48	WORD CLOCK IN (-)
15	CONTROL OUT (+)	49	CONTROL OUT (-)
16	CONTROL IN (+)	50	CONTROL IN (-)
17	GND	51	ID6 OUT
18	GND	52	ID6 IN
19	OUTPUT 17-18 (+)	53	OUTPUT 17-18 (-)
20	OUTPUT 19-20 (+)	54	OUTPUT 19-20 (-)
21	OUTPUT 21-22 (+)	55	OUTPUT 21-22 (-)
22	OUTPUT 23-24 (+)	56	OUTPUT 23-24 (-)
23	OUTPUT 25-26 (+)	57	OUTPUT 25-26 (-)
24	OUTPUT 27-28 (+)	58	OUTPUT 27-28 (-)
25	OUTPUT 29-30 (+)	59	OUTPUT 29-30 (-)
26	OUTPUT 31-32 (+)	60	OUTPUT 31-32 (-)
27	ID0 OUT	61	ID1 OUT
28	ID2 OUT	62	ID3 OUT
29	ID4 OUT	63	ID5 OUT
30	ID0 IN	64	ID1 IN
31	ID2 IN	65	ID3 IN
32	ID4 IN	66	ID5 IN
33	MSB //LSB OUT	67	2CH//4CH OUT
34	FG	68	FG

[NETWORK] Connector (100Base-TX Ethernet, RJ-45)

Pin	Connection
1	TxD+
2	TxD-
3	RxD+
4	Unused
5	Unused
6	RxD-
7	Unused
8	Unused

Straight/Cross Cable Wiring Details**Straight Cables**

Pins
1 — 1
2 — 2
3 — 3
4 — 4
5 — 5
6 — 6
7 — 7
8 — 8

Cross Cables

Pins
1 — 3
2 — 6
3 — 1
4 — 4
5 — 5
6 — 2
7 — 7
8 — 8

Dimensions

Unit: mm

DME64N

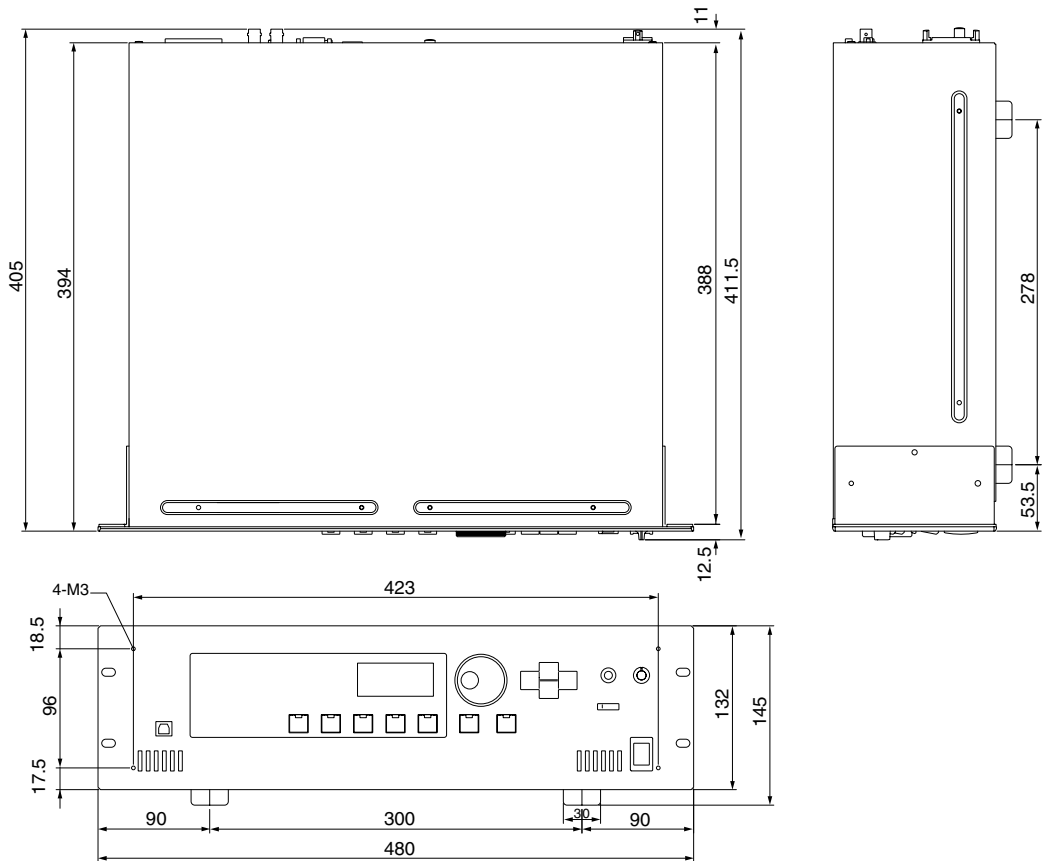

DME24N

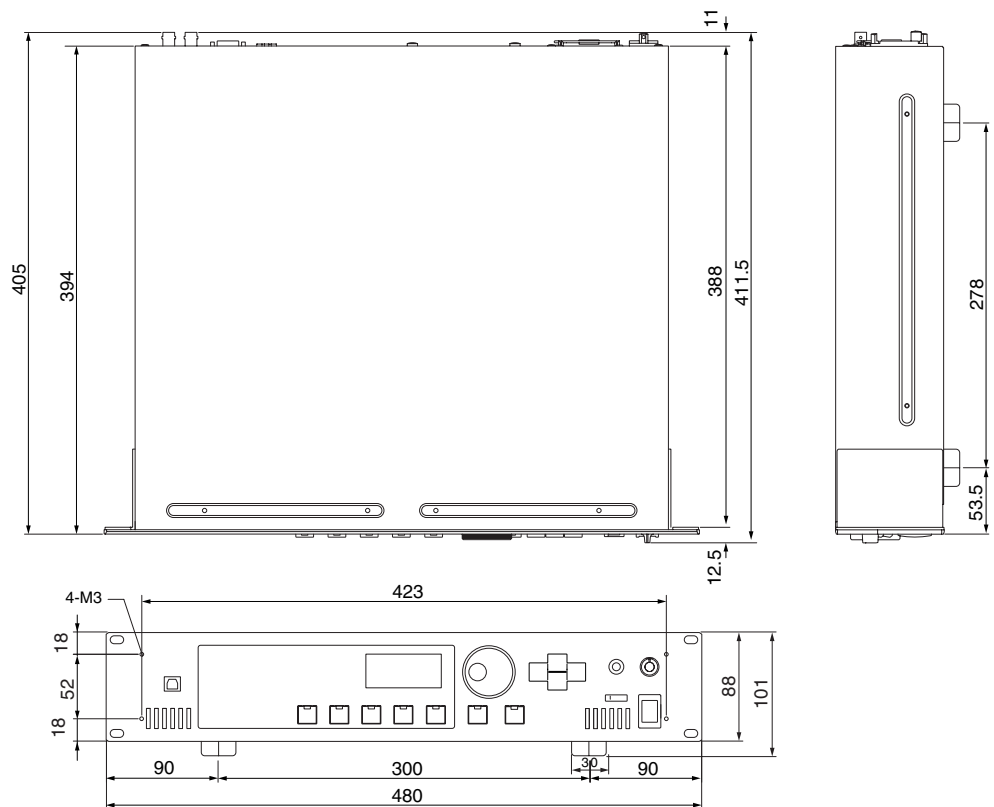

MIDI Data Format

1. DME64N/24N MIDI Functions

1.1 Scene Change

Scene recall occurs according to the “MIDI Program Change Table” assignments when appropriate MIDI Bank Select MSB/LSB and Program Change messages are received by the DME64N/24N.

Corresponding MIDI Bank Select MSB/LSB and Program Change messages are also transmitted by the DME64N/24N when a scene recall operation is carried out via the panel controls, as specified by the “MIDI Program Change Table” assignments.

Transmission does not occur when switching Configurations.

1.2 Parameter Control

MIDI Control Change and Parameter Change messages transmitted to the DME64N/24N can be used to control parameters according to the “MIDI Control Change table” and “MIDI Parameter Change Table” assignments.

Corresponding MIDI Control Change and Parameter Change messages are also transmitted by the DME64N/24N when a parameter is edited out via the panel controls, as specified by the “MIDI Control Change table” and “MIDI Parameter Change Table” assignments.

2. MIDI Data Flow

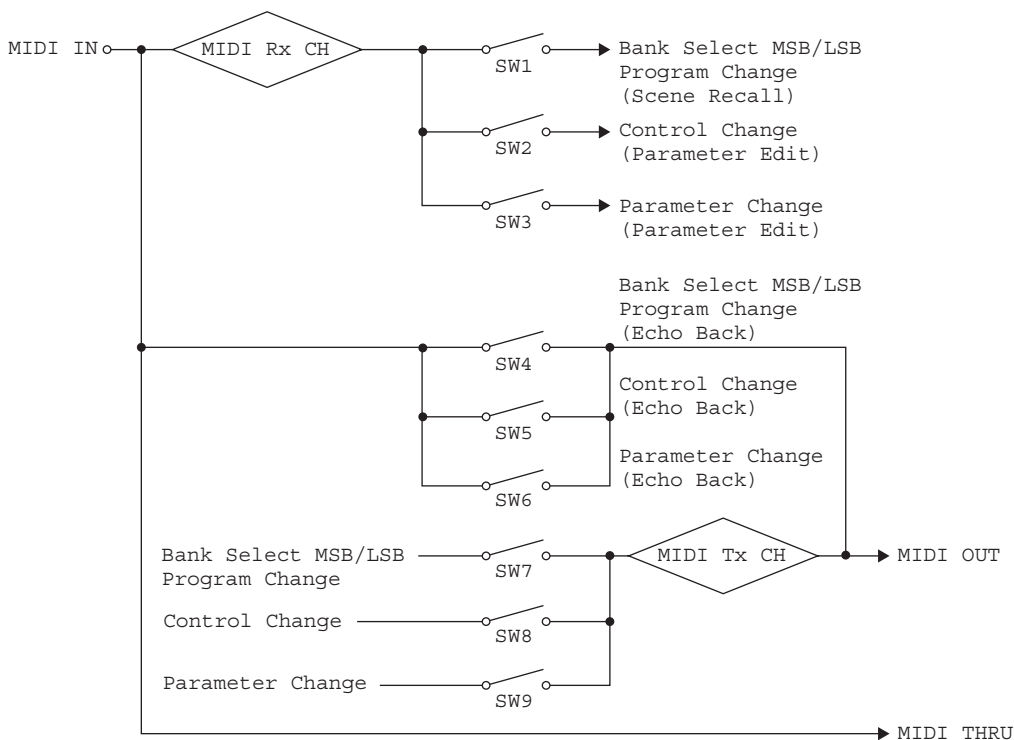

- SW1: Program Change Rx Switch [On/Off]
- SW2: Control Change Rx Switch [On/Off]
- SW3: Parameter Change Rx Switch [On/Off]
- SW4: Program Change Echo Back Switch [On/Off]
- SW5: Control Change Echo Back Switch [On/Off]
- SW6: Parameter Change Echo Back Switch [On/Off]
- SW7: Program Change Tx Switch [On/Off]
- SW8: Control Change Tx Switch [On/Off]
- SW9: Parameter Change
- MIDI Rx CH: MIDI Rx Channel (1-16)
- MIDI Tx CH: MIDI Tx Channel (1-16)

3. MIDI Setup

Specifies basic MIDI operation.

3.1 Host Select

Selects the input/output port to be used for MIDI communication.

3.2 DAW Controller

Specifies the DAW controller type when a DAW control surface is to be used to control the DME64N/24N. When Type 1/2 is selected, Host Select is automatically set to MIDI.

3.3 MIDI Tx Channel

Specifies the MIDI transmit channel (1 - 16).

3.4 MIDI Rx Channel

Specified the MIDI receive channel (1 - 16).

3.5 MIDI Tx Switch

Program Change Tx Switch: turns Bank Select MSB, LSB, and Program Change transmission on or off.

Control Change Tx Switch: turns Control Change transmission on or off.

Parameter Change Tx Switch: turns Parameter Change transmission on or off.

3.6 MIDI Rx Switch

Program Change Rx Switch: turns Bank Select MSB, LSB, and Program Change reception on or off.

Control Change Rx Switch: turns Control Change reception on or off.

Parameter Change Rx Switch: turns Parameter Change reception on or off.

3.7 MIDI Omni Switch

Program Change Omni Switch: turns the Bank Select MSB, LSB, and Program Change omni mode on or off.

Control Change Omni Switch: turns the Control Change omni mode on or off.

3.8 MIDI Echo Back Switch

Program Change Echo Back Switch: turns Bank Select MSB, LSB, and Program Change echo back on or off.

Control Change Echo Back Switch: turns Control Change echo back on or off.

Parameter Change Echo Back Switch: turns Parameter Change echo back on or off.

4. MIDI Format

Number Format Notation

Numbers ending with “h” are in hexadecimal format, while numbers ending with “b” are binary format. Characters “A” through “F” in hexadecimal numbers represent decimal values 10 through 15. Other lowercase characters (usually “n” or “x”) represent any number.

MIDI Format Chart (Rx: receive, Tx: transmit)

	Command	Rx/Tx	Function
Channel Message	Control Change (Bnh)	Rx/Tx	Parameter Change
	Program Change (Cnn)	Rx/Tx	Scene Recall
System Real-time Message	ACTIVE SENSING (FEH)	Rx	MIDI Cable Check
System Exclusive Message	Parameter Change	Rx/Tx	Parameter Change

4.1 Program Change (Cnh)

Receive

When the “Program Change Rx Switch” is on, Program Change messages are received on the MIDI channel specified by the “MIDI Rx Channel” parameter.

If the “Program Change Omni Switch” is also on, however, Program Change messages will be received on all MIDI channels regardless of the “MIDI Rx Channel” setting.

When a Program Change message is received, the scene assigned to the received program number in the “MIDI Program Change table” is recalled.

The accepted Bank Select, Program Change range is as follows:

Bank Select MSB: 0
Bank Select LSB: 0 ~ 7
Program Change No.: 0 ~ 127

Transmit

When the “Program Change Tx Switch” is on, the corresponding Program Change number will be transmitted as specified by the “MIDI Program Change table” and “MIDI Tx Channel” settings.

If multiple Program Change numbers are assigned to a single scene, the Bank Select MSB/LSB and Program Change number corresponding to the lowest number will be transmitted.

Bank Select MSB

Status	Bnh (1101nnnbn)	Control Change
Data	00h (00000000b)	Control Change No. 0 (Bank Select MSB)
Data	nnh (0nnnnnnbn)	Control Value (Bank Select MSB No.)

Bank Select LSB

Status	Bnh (1101nnnbn)	Control Change
Data	20h (00100000b)	Control Change No. 32 (Bank Select LSB)
	nnh (0nnnnnnbn)	Control Value (Bank Select LSB No.)

Program Change No.

Status	Cnh (1100nnnbn)	Program Change
Data	nnh (0nnnnnnbn)	Program Change No. (0-127)

4.2 Active Sensing (FEh)

Receive

MIDI communication will be initialized if no data is received within 300 ms after reception (Running Status, etc., will be cleared).

Active Sensing

Status	FEh (11111110b)	Active Sensing
--------	-----------------	----------------

4.3 Control Change (Bnh)

Receive

When the “Control Change Rx Switch” is on, Control Change messages are received on the MIDI channel specified by the “MIDI Rx Channel” parameter.

If the “Control Change Omni Switch” is also on, however, Control Change messages will be received on all MIDI channels regardless of the “MIDI Rx Channel” setting.

Control Change parameter resolution is 128 regardless of the parameters effective range. For finer settings use Parameter Change.

Transmit

When the “Control Change Tx Switch” is on, appropriate Control Change data will be transmitted when a parameter is edited via the panel controls, as specified by the “MIDI Control Change table” and “MIDI Tx Channel” settings.

Transmission does not occur when switching Configurations.

Refer to “Supplementary Information 1” for cases in which multiple messages are assigned to single parameter.

Status	Bnh (1011nnnbn)	Control Change
Data	cch (0cccccccb)	Control Change No. (1-31, 33-95, 102-119)
	vvh (0vvvvvvvb)	Control Value (0-127)

4.4 Parameter Change (F0h ~ F7h)

Receive

When the “Parameter Change Rx Switch” is On, Parameter Change messages are received on the MIDI channel specified by the “Device ID (Rx Ch)” parameter.

Transmit

When the “Parameter Change Tx Switch” is On, appropriate Parameter Change data will be transmitted when a parameter is edited via the panel controls, as specified by the “MIDI Parameter Change table” and “MIDI Tx Channel” settings. Refer to “Supplemental Information 1” for cases in which multiple messages are assigned to single parameter. Refer to “Supplemental Information 2” for information on setting Parameter Data values.

Status	F0h (11110000b)	System Exclusive Message
ID No.	43h (01000011b)	Manufacturer's ID No. (YAMAHA)
DEVICE ID.	10h (0001xxxxb)	Rx/Tx Channel (0-15)
GROUP ID.	3Eh (00111110b)	Digital Mixer
MODEL ID.	10h (00010000b)	Device Code (DME)
Parameter Address	aah (0aaaaaab)	Parameter Address High
	aah (0aaaaaab)	Parameter Address Low
Parameter Data Value	ddh (0ddddddb)	data 0
	ddh (0ddddddb)	data 1
	ddh (0ddddddb)	data 2
	ddh (0ddddddb)	data 3
	ddh (0ddddddb)	data 4
EOX	F7h (11110111b)	End of Exclusive

Supplemental Information 1

Messages Transmitted When Multiple Messages are Assigned to the Same Parameter

The DME64N/24N MIDI transmit messages are specified via the “MIDI Control Change Table” and “MIDI Parameter Change Table.” The “MIDI Control Change Table” and “MIDI Parameter Change Table” can be set up via the DME Designer application.

Multiple messages can be assigned to a single parameter, but the DME64N/24N will only transmit one of the assigned messages.

The transmitted messages are as follows:

- If a Control Change message and a Parameter Change message are assigned to the same parameter → the Control Change message will be transmitted.
- If multiple Control Change numbers are assigned to the same parameter → the smallest Control Change number message will be transmitted.
- If multiple Parameter Change numbers are assigned to the same parameter → the smallest Parameter Change number message will be transmitted.

Supplemental Information 2

Setting the Parameter Change Message Parameter Data Values

The Parameter change parameter values are expressed as 32-bit integers with or without parity.

- A parity bit (positive: 0, negative: 1) is added above the most significant value bit (bit 31).
- Fractional parameters will be converted according to the integer table.
- For integers with parity, negative numbers are expressed as the 2’s complement.

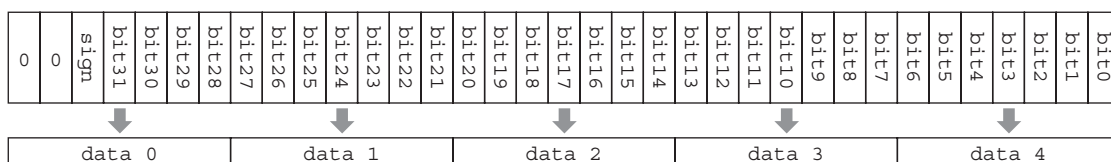

Example

- When value is 1000 (decimal) / 3E8h (hexadecimal):

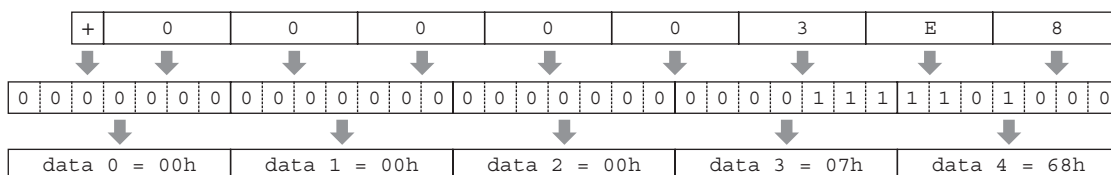

- When value is 1000 (decimal) / FFFFC18h (hexadecimal; 2’s complement of 3E8h):

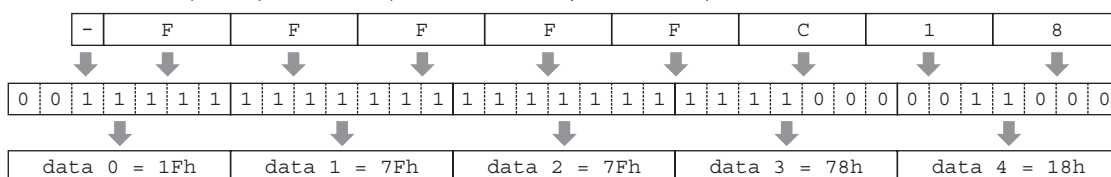

YAMAHA [Digital Mixing Engine]
Model DME64N/24N MIDI Implementation Chart

Date :31-MAR-2004
Version : 1.0

Function...	Transmitted	Recognized	Remarks
Basic Channel	Default Changed 1 - 16 1 - 16	1 - 16 1 - 16	Memorized
Mode	Default Messages Altered X X *****	X X X	
Note Number : True voice	X *****	X X	
Velocity	Note ON Note OFF X X	X X	
After Touch	Key's Ch's X X	X X	
Pitch Bend	X	X	
Control Change	0,32 1-31,33-95,102-119 O *1 O *2	O *1 O *2	Bank Select Assignable
Prog Change : True #	O 0 - 127 *1 *****	O 0 - 127 *1 0 - 127	
System Exclusive	O *3	O *3	Assignable
Common : Song Pos. : Song Sel. : Tune	X X X	X X X	
System : Clock Real Time : Commands	X X	X X	
Aux : All Sound Off : Reset All Cntrls : Local ON/OFF Mes- : All Notes OFF sages: Active Sense : Reset	X X X X X X	X X X X O X	
<p>Notes: not include "DAW controller" command</p> <p>*1 transmit/receive if program change switch is on. *2 transmit/receive if control change switch is on. *3 transmit/receive if parameter change switch is on.</p>			

Mode 1 : OMNI ON , POLY
Mode 3 : OMNI OFF, POLY

Mode 2 : OMNI ON ,MONO
Mode 4 : OMNI OFF,MONO

O : Yes
X : No

References

Glossary

Terms	Explanations
100Base-TX	A physical specification for a 100 Mbps Ethernet network connection using 2-conductor Category 5 UTP cable included in the IEEE 802.3u standard. Maximum data transfer distance is 100 meters.
10Base-T	A physical specification for a 10 Mbps Ethernet network connection using 2-conductor Category 3 UTP cable included in the IEEE 802.3i standard. Maximum data transfer distance is 100 meters.
ADAT (Alesis Digital Audio Tape)	A digital audio connection format used by ADAT compliant digital audio devices. Eight channels of digital audio can be carried by a single optical "Tos-Link" cable.
AES/EBU (Audio Engineering Society/ European Broadcasting Union)	A digital audio format jointly devised by the AES and EBU. Used primarily for digital audio transfer between professional equipment. Two channels of digital audio can be handled via a single connector (Left: odd number, Right: even number). Standard XLR connectors are generally used for this type of connection.
BNC (Bayonet Nut Connector, or Bayonet Neill Concelman)	A type of connector used for high-frequency connections using thin-core coaxial cable. An internal spring ensures a solid connection.
Cascade	A means of connecting Yamaha digital audio equipment to allow transfer of audio, control, and word clock signals. Yamaha cascade connections employ half-pitch 68-pin D-Sub connectors.
Category 3	Electrical specifications for one type of UTP cable jointly developed by the TIA (Telecommunications Industry Association) and EIA (Electronic Industry Alliance). Several categories are specified according to electrical characteristics, with higher category numbers denoting higher quality cable. Category 3 cable can be used for transmission speeds up to 10 MHz.
Category 5	Electrical specifications for one type of UTP cable jointly developed by the TIA (Telecommunications Industry Association) and EIA (Electronic Industry Alliance). Several categories are specified according to electrical characteristics, with higher category numbers denoting higher quality cable. Category 5 cable can be used for transmission speeds up to 100 MHz.
CobraNet	An audio networking system developed by Peak Audio (a division of Cirrus Logic, Inc.) that allows real-time transmission and reception of multiple channels of uncompressed digital audio signals via a Fast Ethernet (100 megabits/sec.) network.
Component	The basic modules that are combined to create DME64N/24N audio systems. In addition to complete audio processors such as mixers, compressors, effects, crossovers, etc., a range of smaller functions such as faders, switches, pan controls, and meters are also available. Components can also be customized.
Configuration	A set of components and connections that make up an audio system in the DME64N/24N.
D-Sub	Another common form of connector that gets its name from the "D" shape of the connector. This type of connector can be securely attached using screws. Individual "pins" are used to connect each of the cable's conductors. D-Sub connectors come in 9-pin, 15-pin, 25-pin, 37-pin, and other sizes.
DSP (Digital Signal processor)	A semiconductor chip (LSI), or device containing one or more such chips, developed specifically to process large volumes of data in real time. Ideal for processing digital audio.
Ethernet	A network protocol jointly developed by the Xerox, DEC, and Intel corporations, and codified in the IEEE 802.3 industry standard. Transfer speeds have increased to 100 Mbps, 1000 Mbps, and 10 Gbps from the initial 10 Mbps, while maintaining network compatibility.
Ethersound	An audio networking system developed by Digigram Corporation. It transmits uncompressed digital audio signals via Ethernet.
Euroblock	A connector system consisting of plug and socket components that allows easy, solder-less wiring for a range of installations and devices. Simply insert the wire into the plug slot, tighten the screw, and plug into the socket to complete the connection.
GPI (General Purpose Interface)	A general-purpose control interface that can be used to allow control of the DME64N/24N via external devices and custom-made controllers. Connections are made via a Euroblock connector. The optional CP4SW, CP1SF, and CP4SF control panels also connect via GPI.
Initial Settings	The initial values and settings of all editable parameters that will be in effect when a device is powered on for the first time after it is shipped from the factory. Also known as "default settings" or "initial factory settings."
MAC (Media Access Control) Address	The MAC address is also known as the Ethernet address, and is an independent address assigned to all Ethernet devices worldwide. No two devices can have the same address.
MIDI (Musical Instrument Digital Interface)	An international standard for data communication between electronic musical instruments and audio devices.
Mini YGDAI (Yamaha General Digital Audio Interface) card	A standard for I/O cards that can be installed to Yamaha audio products.

Terms	Explanations
Phantom Power	A power delivery system that allows power to be delivered to devices along with audio signals via standard balanced audio cables. The term "phantom" is applied because the system uses the audio conductors for power delivery without disrupting the audio signal – the power is not "seen" by the audio signal.
Preset Parameter	The parameter set of all components included in a configuration.
RJ-45	An 8-conductor modular connector used for Ethernet cable and ISDN telephone connections. The appearance is similar to the RJ-11 connectors used for telephone lines, but the connector is actually somewhat larger. "RJ" stands for "Registered Jack," and is a connector type included in the Bell System USOC (Universal Service Ordering Codes) standards.
Router	An equipment that relays data in network by selecting the most effective route.
RS-232C	A serial communication protocol that allows data transfer over distances of up to 15 meters. RS232C interfaces usually employ 9-pin D-sub connectors. "RS" stands for "Recommended Standard," and one of the standards developed by the EIA (Electronic Industry Alliance).
RS-422	A balanced serial communication protocol that allows data transfer over distances of up to 1 kilometer. RS-422 offers higher data rates and greater reliability than the RS-232C protocol.
Sampling Frequency	The number of times per second an analog audio signal is "sampled" when it is being converted to digital audio.
Scene	A complete audio setup including configuration data and the related component preset parameters. Up to 999 scenes can be stored for each zone in a DME64N/24N audio system.
STP (Shielded Twisted Pair) Cable	A data transmission cable consisting of a shielded twisted pair. This type of cable is more resistant to noise and interference than UTP (Unshielded Twisted Pair) cable.
Switching Hub	A network hub which automatically connects only ports through which communication is currently taking place. This reduces network load while maximizing security. This type of hub can often mediate between devices having different transmission speeds and standards.
TDIF (Tascam Digital Interface Format)	A digital interface standard used by the TEAC corporation (TASCAM). Eight channels of digital audio input and output are handled via a 25-pin D-Sub connector.
USB (Universal Serial Bus)	A serial bus primarily used for connecting peripheral devices to computer equipment. The USB 1.1 standard allows data transfer rates of up to 12 Mbps.
UTP (Unshielded Twisted pair) Cable	A data transmission cable consisting of an unshielded twisted pair. This type of cable is less expensive and more commonly available than STP (Shielded Twisted Pair) cable, and is widely used in 10Base-T and 100Base-TX network connections.
Word Clock	A signal used to synchronize multiple interconnected digital audio devices. The word clock frequency will be the same as the sampling frequency of the audio signal being processed.

Index

+48V	55
[◀][▲][▼][▶] Buttons	15
100Base-TX (Glossary)	73
10Base-T (Glossary)	73
[96kHz] [88.2kHz] [48kHz] [44.1kHz] Indicator	14

A

[AC IN] Connector	16
ADAT (Alesis Digital Audio Tape) (Glossary)	73
AES/EBU (Audio Engineering Society/European Broadcasting Union) (Glossary)	73
area	9
audio	11

B

Band Output Level	41
Battery	46
BNC (Bayonet Nut Connector, or Bayonet Neill Concelman) (Glossary)	73

C

cable clamp	18
Calibration Info	53
[CANCEL] Button	15
Card Name	51
CASCAD Page	55
Cascade (Glossary)	73
Cascade (WCLK Page)	50
CASCADE connection	31
[CASCADE IN] [CASCADE OUT] Connectors	17, 31
cascade loop	31
Cascade Setup (CASCAD) Page	55
Category 3 (Glossary)	73
Category 5 (Glossary)	73
CH (Double Channel) (Slot Page)	51
CH (MIDI Page)	52
CobraNet (Glossary)	73
component (Glossary)	73
Components	9
Configuration	9
configuration (Glossary)	73
connector pin assign	65
Control Change	52
control I/O	63
CP4SW, CP4SF, and CP1SF	57

D

Date	46
DAW	51
Device control	11

device group	9
Device Group (Net Page)	47
Device group control	11
Dial	15
dimensions	67
Disp Page	47
Display	15
Display Setup (Disp) Page	47
DME Designer	13
DME-N Network Driver	23
DSP (Digital Signal processor) (Glossary)	73
D-Sub (Glossary)	73

E

[ENTER] Button	15
Error Messages	58
Ethernet (Glossary)	73
Ethernet Connection	23
Euroblock	26
Euroblock (Glossary)	73
[EXT. CLOCK] Indicator	14

F

Format (HA Page)	54
Format (Slot Page)	51
Frequency	41
front panel	14
Frq	55
Fs	50

G

Gain	55
GPI (General Purpose Interface)	33
GPI (General Purpose Interface) (Glossary)	73
GPI connection	33
[GPI] Connector	16, 33
Ground Screw	16

H

HA	54
HA Page	54
Head Amplifier Setup (HA) Page	54, 56
Head Margin	55
High-pass Filter	55
High-pass Filter Frequency	55
[HOME] Button	15
Host	51
HPF	55

I	
I/O card	20
I/O card (installation procedure)	21
I/O Slots	17
ICP1	57
[IN] [OUT] Connectors	17, 26
Info Page	46
initial settings (Glossary)	73
Input/Output Level Display	42
Int	50
IP Adr.	47

L	
L/R Select	42
Label	46
LCD Backlight	48
LCD Contrast	47
[LEVEL] Button	15
Level Meter display	42
Link Mode	47
List Parameter	38
Lock Page	48

M	
MAC (Media Access Control) Address (Glossary)	73
MAC Adr.	47
Main display	35
[MASTER] Indicator	15
MAX	53
Meter Fall Time	48
MIDI (Musical Instrument Digital Interface) (Glossary)	73
MIDI connection	30
MIDI Data Format	68
[MIDI IN] [MIDI OUT] [MIDI THRU] Connectors	17
[MIDI] Indicator	15
MIDI Page	51
MIDI Setup (MIDI) Page	51
MIN	53
Mini YGDAI (Yamaha General Digital Audio Interface) card (Glossary)	73
Misc Page	49
Miscellaneous Setup (Misc) Page	49
Mixer I/O	56
[MONITOR] Button	15
Monitoring	40
[MUTE] Button	15
Mute Indicator	35
Mute Switching	39

N	
Net Page	47
[NETWORK] Connector	17, 23
[NETWORK] Indicator	14
Network Settings	22
Network Settings (Net) Page	47

Numeric Parameter	36
-------------------------	----

O	
ON/OFF Parameter	38
Options	57
Output Level Control	39
Output Level Indicator	35

P	
Page Scroll Bar	35
Panel Lock	36
Panel Lock Boot	48
Panel Lock Icon	35
Panel Lock Target	48
Parameter Change	52
Parameter Edit display	36
Peak Hold (Level Meter display)	42
Peak Hold (Spectrum display)	41
[PEAK] Indicator	15
Phantom Master Switch	55
Phantom Power (Glossary)	74
[PHONES] Jack	15
[PHONES LEVEL] Control	15
[POWER] Switch	15
preparation	18, 26
preset parameter (Glossary)	74
Probe Monitor Function	41
Program Change	52

R	
rear panel	16
Remote (Misc Page)	49
Remote Connection	28
[REMOTE] Connector	17, 28
Reset (GPI Page)	53
Reset (Slot Page)	51
RJ-45 (Glossary)	74
router (Glossary)	74
RS-232C (Glossary)	74
RS-422 (Glossary)	74

S	
sampling frequency (Glossary)	74
Scene	10
scene (Glossary)	74
Scene Information	35
[SCENE NUMBER] Indicator	15
Scene Recall	39
Scene Store (Misc Page)	49
Scene Store (Operation)	40
security cover mounting	18
Security Setup (Lock) Page	48
[SIGNAL] Indicator	15
Slot Information (Slot) Page	51
Slot Page	51

SLOT1-4	50
SP (Double Speed)	51
specifications	62
Spectrum display	41
status message	58
STP (Shielded Twisted Pair) Cable (Glossary)	74
Switching Hub (Glossary)	74

T

TDIF (Tascam Digital Interface Format) (Glossary)	74
troubleshooting	61

U

Unit No	55
USB (Universal Serial Bus) (Glossary)	74
USB Connection	22
[USB] Connector	14
USB-MIDI Driver	22
User Defined button	9
User Defined Button (Edit)	38
User Defined Button Names	35
User Defined buttons (User Defined parameters)	9
User Defined Lock	48
Utility (Lock Page)	48
[UTILITY] Button	15
Utility display	44
Utility display (Operation)	46
UTP (Unshielded Twisted pair) Cable (Glossary)	74

V

Version	46
---------------	----

W

WCIN	50
WCLK (HA Page)	54
WCLK Page	50
Word Clock (Glossary)	74
WORD CLOCK connection	32
[WORD CLOCK IN] [WORD CLOCK OUT] Connectors	17, 32
word clock master	32
Word Clock Setup (WCLK) Page	50
word clock slave	32

Z

zones	9
-------------	---

MEMO

For details of products, please contact your nearest Yamaha representative or the authorized distributor listed below.

Pour plus de détails sur les produits, veuillez-vous adresser à Yamaha ou au distributeur le plus proche de vous figurant dans la liste suivante.

Die Einzelheiten zu Produkten sind bei Ihrer unten aufgeführten Niederlassung und bei Yamaha Vertragshändlern in den jeweiligen Bestimmungsländern erhältlich.

Para detalles sobre productos, contacte su tienda Yamaha más cercana o el distribuidor autorizado que se lista debajo.

NORTH AMERICA

CANADA

Yamaha Canada Music Ltd.
135 Milner Avenue, Scarborough, Ontario,
M1S 3R1, Canada
Tel: 416-298-1311

U.S.A.

Yamaha Corporation of America
6600 Orangethorpe Ave., Buena Park, Calif. 90620,
U.S.A.
Tel: 714-522-9011

CENTRAL & SOUTH AMERICA

MEXICO

Yamaha de México S.A. de C.V.
Calz. Javier Rojo Gómez #1149,
Col. Guadalupe del Moral
C.P. 09300, México, D.F., México
Tel: 55-5804-0600

BRAZIL

Yamaha Musical do Brasil Ltda.
Rua Joaquim Floriano, 913 - 4º andar, Itaim Bibi,
CEP 04534-013 Sao Paulo, SP. BRAZIL
Tel: 011-3704-1377

ARGENTINA

Yamaha Music Latin America, S.A.
Sucursal de Argentina
Olga Cossetini 1553, Piso 4 Norte
Madero Este-C1107CEK
Buenos Aires, Argentina
Tel: 011-4119-7000

PANAMA AND OTHER LATIN AMERICAN COUNTRIES/ CARIBBEAN COUNTRIES

Yamaha Music Latin America, S.A.
Torre Banco General, Piso 7, Urbanización Marbella,
Calle 47 y Aquilino, de la Guardia,
Ciudad de Panamá, Panamá
Tel: +507-269-5311

EUROPE

THE UNITED KINGDOM

Yamaha Music U.K. Ltd.
Sherbourne Drive, Tilbrook, Milton Keynes,
MK7 8BL, England
Tel: 01908-366700

GERMANY

Yamaha Music Europe GmbH
Siemensstraße 22-34, 25462 Rellingen, Germany
Tel: 04101-3030

SWITZERLAND/LIECHTENSTEIN

Yamaha Music Europe GmbH
Branch Switzerland in Zürich
Seefeldstrasse 94, 8008 Zürich, Switzerland
Tel: 01-383 3990

AUSTRIA

Yamaha Music Europe GmbH Branch Austria
Schleiergasse 20, A-1100 Wien, Austria
Tel: 01-60203900

CZECH REPUBLIC/SLOVAKIA/ HUNGARY/SLOVENIA

Yamaha Music Europe GmbH Branch Austria
Schleiergasse 20, A-1100 Wien, Austria
Tel: 01-602039025

POLAND

Yamaha Music Europe GmbH
Branch Sp.z o.o. Oddział w Polsce
ul. 17 Stycznia 56, PL-02-146 Warszawa, Poland
Tel: 022-868-07-57

THE NETHERLANDS/ BELGIUM/LUXEMBOURG

Yamaha Music Europe Branch Benelux
Clarissenhof 5-b, 4133 AB Vianen, The Netherlands
Tel: 0347-358 040

FRANCE

Yamaha Musique France
BP 70-77312 Marne-la-Vallée Cedex 2, France
Tel: 01-64-61-4000

ITALY

Yamaha Musica Italia S.P.A.
Combo Division
Viale Italia 88, 20020 Lainate (Milano), Italy
Tel: 02-935-771

SPAIN/PORTUGAL

Yamaha Música Ibérica, S.A.
Ctra. de la Coruna km. 17, 200, 28230
Las Rozas (Madrid), Spain
Tel: 91-639-8888

SWEDEN

Yamaha Scandinavia AB
J. A. Wettergrens Gata 1, Box 30053
S-400 43 Göteborg, Sweden
Tel: 031 89 34 00

DENMARK

YS Copenhagen Liaison Office
Generatorvej 6A, DK-2730 Herlev, Denmark
Tel: 44 92 49 00

NORWAY

Norsk filial av Yamaha Scandinavia AB
Grini Næringspark 1, N-1345 Østerås, Norway
Tel: 67 16 77 70

RUSSIA

Yamaha Music (Russia)
Office 4015, entrance 2, 21/5 Kuznetskii
Most street, Moscow, 107996, Russia
Tel: 495 626 0660

OTHER EUROPEAN COUNTRIES

Yamaha Music Europe GmbH
Siemensstraße 22-34, 25462 Rellingen, Germany
Tel: +49-4101-3030

AFRICA

Yamaha Corporation,
Asia-Pacific Music Marketing Group
Nakazawa-cho 10-1, Naka-ku, Hamamatsu,
Japan 430-8650
Tel: +81-53-460-2313

MIDDLE EAST

TURKEY/CYPRUS

Yamaha Music Europe GmbH
Siemensstraße 22-34, 25462 Rellingen, Germany
Tel: 04101-3030

OTHER COUNTRIES

Yamaha Music Gulf FZE
LOB 16-513, P.O.Box 17328, Jubel Ali,
Dubai, United Arab Emirates
Tel: +971-4-881-5868

ASIA

THE PEOPLE'S REPUBLIC OF CHINA

Yamaha Music & Electronics (China) Co., Ltd.
2F, Yunhedasha, 1818 Xinzha-lu, Jingan-qu,
Shanghai, China
Tel: 021-6247-2211

INDIA

Yamaha Music India Pvt. Ltd.
5F Ambience Corporate Tower Ambience Mall Complex
Ambience Island, NH-8, Gurgaon-122001, Haryana, India
Tel: 0124-466-5551

INDONESIA

PT. Yamaha Music Indonesia (Distributor)
PT. Nusantik
Gedung Yamaha Music Center, Jalan Jend. Gatot
Subroto Kav. 4, Jakarta 12930, Indonesia
Tel: 21-520-2577

KOREA

Yamaha Music Korea Ltd.
8F, 9F, Dongsung Bldg. 158-9 Samsung-Dong,
Kangnam-Gu, Seoul, Korea
Tel: 080-004-0022

MALAYSIA

Yamaha Music Malaysia, Sdn., Bhd.
Lot 8, Jalan Perbandaran, 47301 Kelana Jaya,
Petaling Jaya, Selangor, Malaysia
Tel: 3-78030900

SINGAPORE

Yamaha Music Asia Pte., Ltd.
#03-11 A-Z Building
140 Paya Lebar Road, Singapore 409015
Tel: 747-4374

TAIWAN

Yamaha KHS Music Co., Ltd.
3F, #6, Sec.2, Nan Jing E. Rd. Taipei.
Taiwan 104, R.O.C.
Tel: 02-2511-8688

THAILAND

Siam Music Yamaha Co., Ltd.
4, 6, 15 and 16th floor, Siam Motors Building,
891/1 Rama 1 Road, Wangmai,
Pathumwan, Bangkok 10330, Thailand
Tel: 02-215-2626

OTHER ASIAN COUNTRIES

Yamaha Corporation,
Asia-Pacific Music Marketing Group
Nakazawa-cho 10-1, Naka-ku, Hamamatsu,
Japan 430-8650
Tel: +81-53-460-2317

OCEANIA

AUSTRALIA

Yamaha Music Australia Pty. Ltd.
Level 1, 99 Queensbridge Street, Southbank,
Victoria 3006, Australia
Tel: 3-9693-5111

COUNTRIES AND TRUST TERRITORIES IN PACIFIC OCEAN

Yamaha Corporation,
Asia-Pacific Music Marketing Group
Nakazawa-cho 10-1, Naka-ku, Hamamatsu,
Japan 430-8650
Tel: +81-53-460-2313

HEAD OFFICE Yamaha Corporation, Pro Audio & Digital Musical Instrument Division
Nakazawa-cho 10-1, Naka-ku, Hamamatsu, Japan 430-8650
Tel: +81-53-460-2441



Yamaha Pro Audio global web site:
<http://www.yamahaproaudio.com/>
Yamaha Manual Library
<http://www.yamaha.co.jp/manual/>

U.R.G., Pro Audio & Digital Musical Instrument Division, Yamaha Corporation
© 2004 Yamaha Corporation
WK83840 906MWCPx.x-02E0
Printed in Japan